

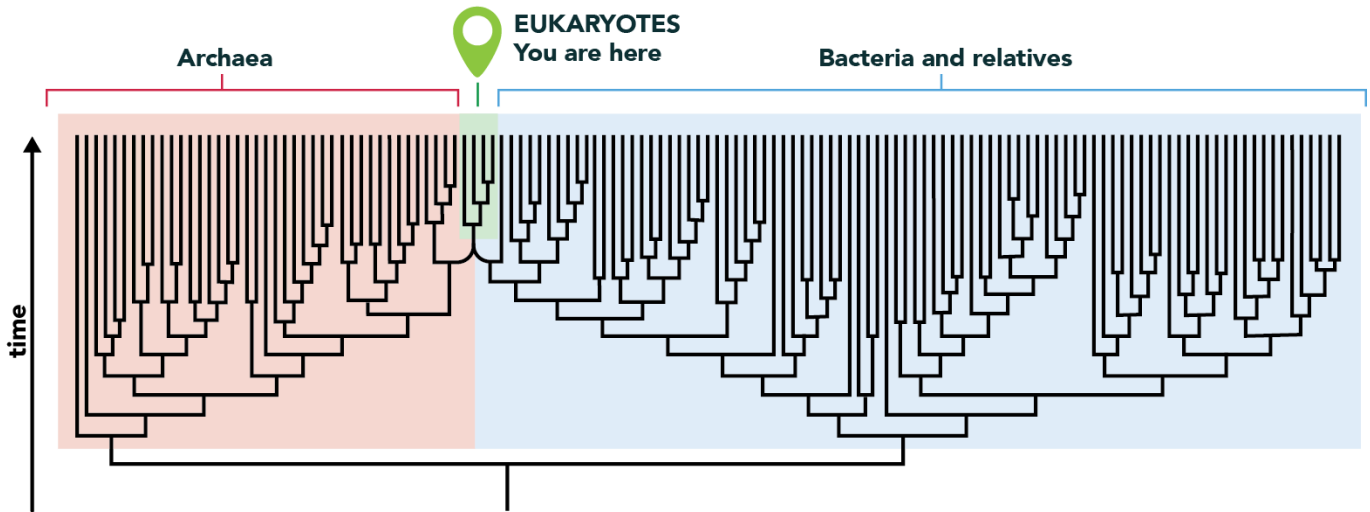

## Evolution 101

What is evolution and how does it work? Evolution 101 provides the nuts-and-bolts on the patterns and mechanisms of evolution. You can explore the following sections:



Tree of Life adapted from Hug et al. (2016)

*Large evolutionary tree showing Bacteria and relatives, Archaea, and Eukaryotes. Eukaryotes is highlighted green, is the smallest of the groups, and has a label stating "You are here."*

- **[An introduction to evolution](#)**  
Evolution briefly defined and explained
- **[The history of life: looking at the patterns](#)**  
How does evolution lead to the tree of life?
- **[Mechanisms: the processes of evolution](#)**  
How does evolution work?
- **[Microevolution](#)**  
How does evolution work on a small scale?
- **[Speciation](#)**  
What are species anyway, and how do new ones evolve?
- **[Macroevolution](#)**  
How does evolution work on a grand scale?
- **[The big issues](#)**  
What are some of the big questions that evolutionary biologists are trying to answer?



## The definition

Biological evolution, simply put, is descent with inherited modification. This definition encompasses everything from small-scale evolution (for example, changes in the frequency of different gene versions in a population from one generation to the next) to large-scale evolution (for example, the descent of different species from a shared ancestor over many generations). Evolution helps us to understand the living world around us, as well as its history.

## The explanation

Biological evolution is not simply a matter of change over time. Many things change over time: caterpillars turn into moths, trees lose and regrow their leaves, mountain ranges rise and erode, but they aren't examples of biological evolution because they don't involve descent with inherited modifications.

All life on Earth shares a common ancestor, just as you and your cousins share a common grandmother. Through the process of descent with modification, this common ancestor gave rise to the diverse species that we see documented in the fossil record and around us today. Evolution means that we're all distant cousins: humans and oak trees, hummingbirds and whales.

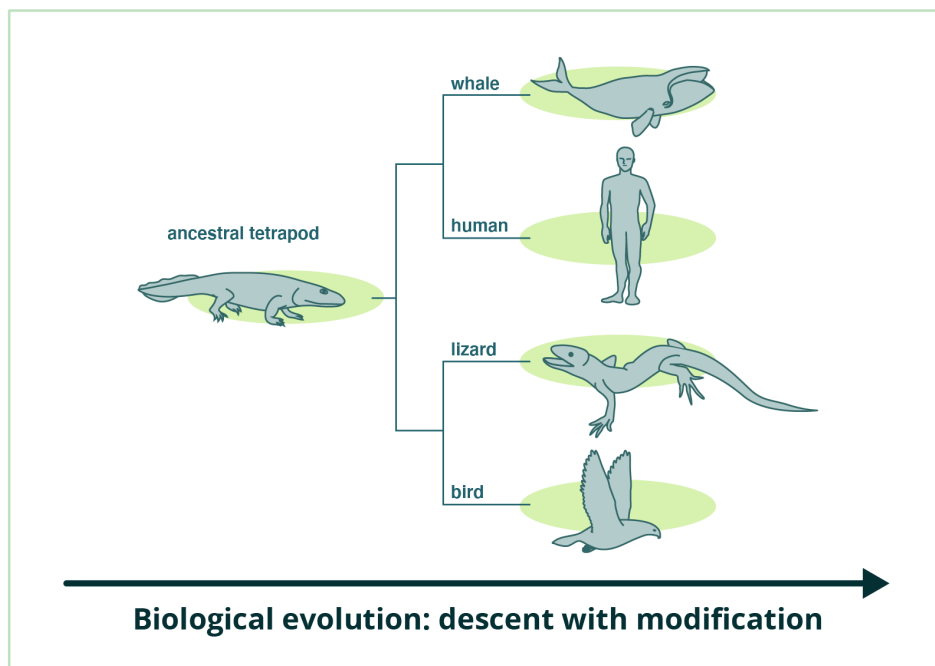

Four seasons photo credit Joisey Showaa, illustration UCMP.



## The history of life: looking at the patterns

The central ideas of evolution are that life has a history — it has changed over time — and that different species share common ancestors.

Here, you can explore how evolutionary change and evolutionary relationships are represented in “family trees,” how these trees are constructed, and how this knowledge affects biological classification. You will also find a timeline of evolutionary history and information on some specific events in the history of life: human evolution and the origin of life.

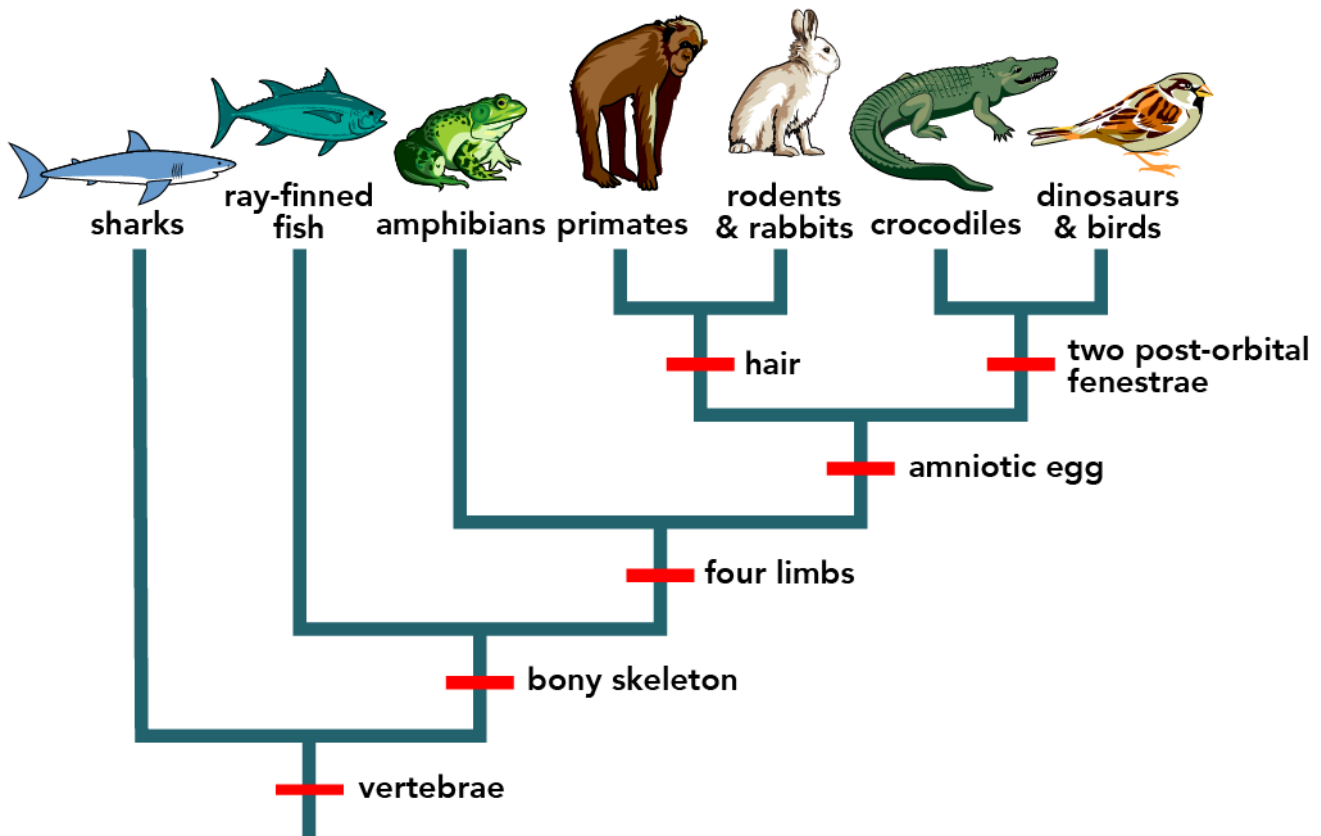

## The family tree

The process of evolution produces a pattern of relationships between species. As lineages evolve and split and modifications are inherited, their evolutionary paths diverge. This produces a branching pattern of evolutionary relationships.

By studying inherited species’ characteristics and other historical evidence, we can reconstruct evolutionary relationships and represent them on a “family tree,” called a phylogeny. The phylogeny you see below represents the basic relationships that tie all life on Earth together.

This tree, like all phylogenetic trees, is a hypothesis about the relationships among organisms. It illustrates the idea that all of life is related. As shown below, we can zoom in on particular branches of the tree to explore the phylogeny of particular lineages, for example, the eukaryotes. And then we can zoom in even further to examine some of the major lineages within Eukaryota, for example, the Opisthokonta...and so on.

# Evolution 101: The history of life: looking at the patterns

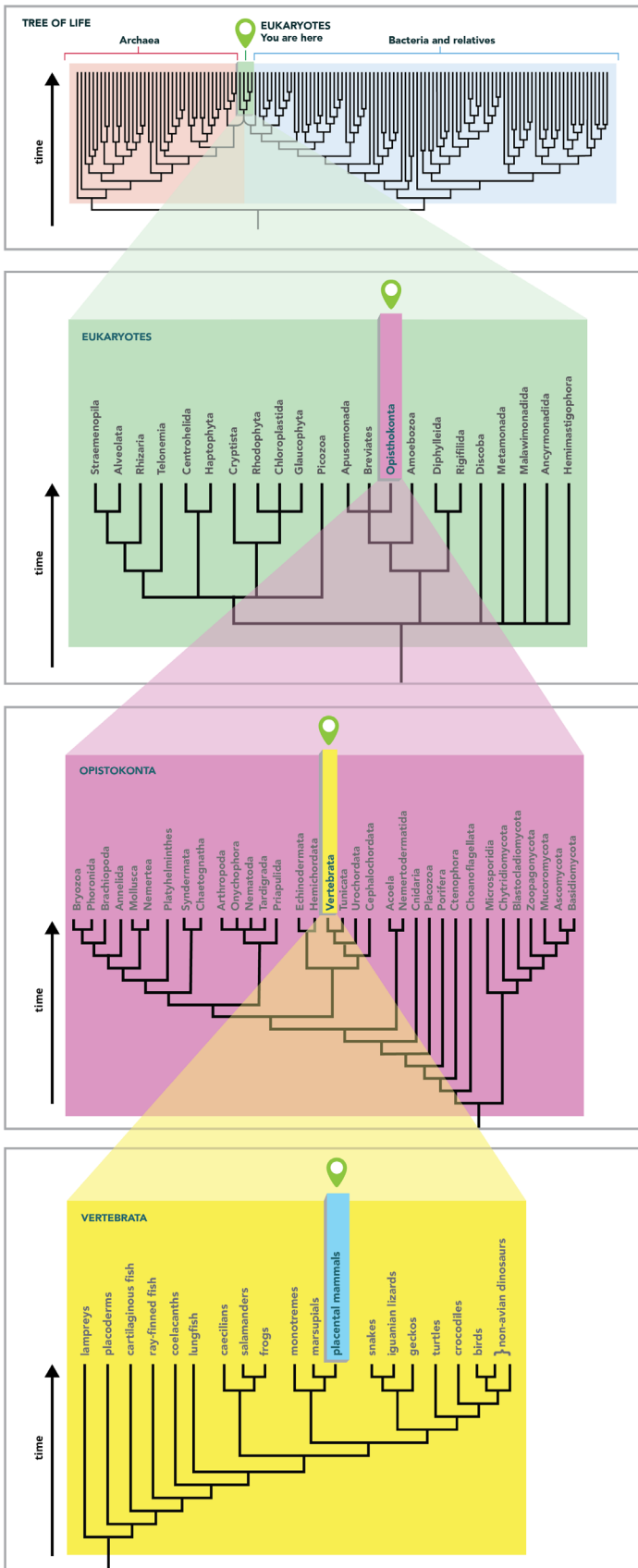

The tree is supported by many lines of evidence, but it is probably not flawless. Scientists constantly reevaluate hypotheses and compare them to new evidence. As scientists gather even more data, they may revise these particular hypotheses, rearranging some of the branches on the tree. For example, evidence discovered in the last 50 years suggests that birds are dinosaurs, which required adjustment to several “vertebrate twigs.”

Tree of Life adapted from Hug et al. (2016)



## Understanding phylogenies

Understanding a phylogeny is a lot like reading a family tree. The root of the tree represents the ancestral lineage, and the tips of the branches represent the descendants of that ancestor. As you move from the root to the tips, you are moving forward in time.

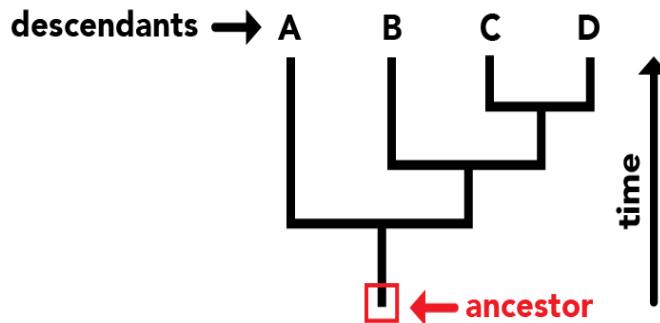

When a lineage splits (speciation), it is represented as branching on a phylogeny. When a speciation event occurs, a single ancestral lineage gives rise to two or more daughter lineages.

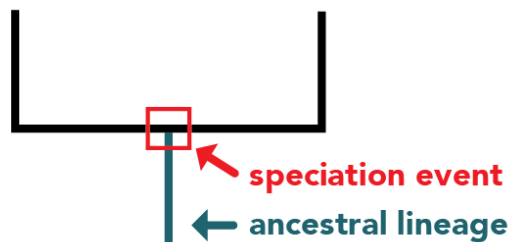

Phylogenies trace patterns of shared ancestry between lineages. Each lineage has a part of its history that is unique to it alone and parts that are shared with other lineages.

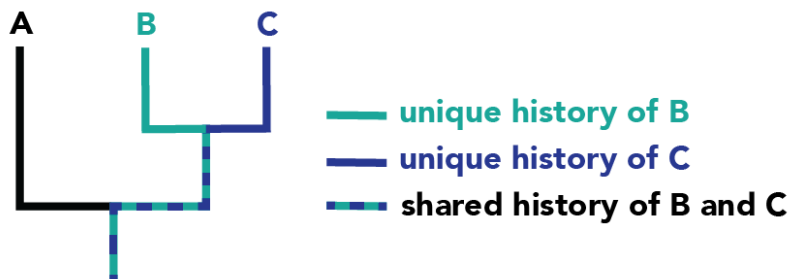

Similarly, each lineage has ancestors that are unique to that lineage and ancestors that are shared with other lineages — common ancestors.

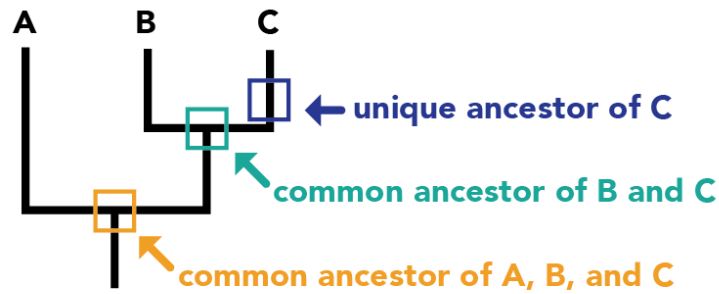

A clade is a grouping that includes a common ancestor and all the descendants (living and extinct) of that ancestor. Using a phylogeny, it is easy to tell if a group of lineages forms a clade. Imagine clipping a single branch off the phylogeny — all of the organisms on that pruned branch make up a clade.

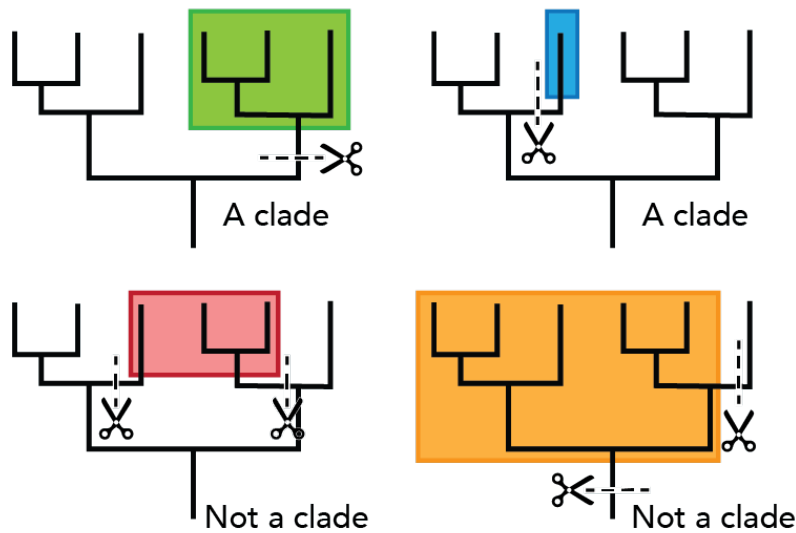

Clades are nested within one another — they form a nested hierarchy. A clade may include many thousands of species or just a few. Some examples of clades at different levels are marked on the phylogenies below. Notice how clades are nested within larger clades.

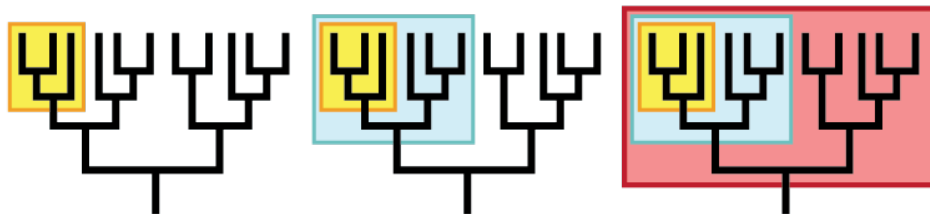

So far, we've said that the tips of a phylogeny represent descendent lineages. Depending on how many branches of the tree you are including however, the descendants at the tips might be different populations of a species, different species, or different clades, each composed of many species.



## Trees, not ladders

Several times in the past, biologists have committed themselves to the erroneous idea that life can be organized on a ladder of lower to higher organisms. This idea lies at the heart of Aristotle's Great Chain of Being (see right).

Similarly, it's easy to misinterpret phylogenies as implying that some organisms are more "advanced" than others; however, phylogenies don't imply this at all.

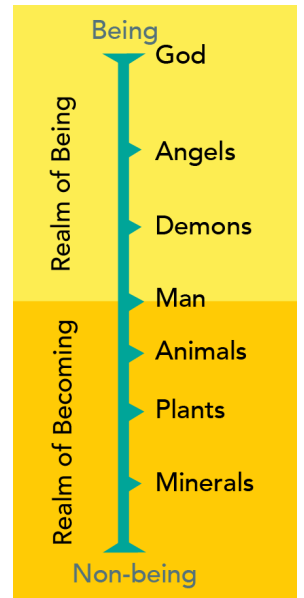

Aristotle's vision of a Great Chain of Being, above. We now know that this idea is incorrect.

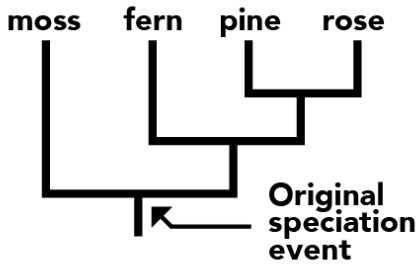

In this highly simplified phylogeny, a speciation event occurred resulting in two lineages. One led to the mosses of today; the other led to the fern, pine, and rose. Since that speciation event, both lineages have had an equal amount of time to evolve. So, although mosses branch off early on the tree of life and share many features with the ancestor of all land plants, living moss species are not ancestral to other land plants. Nor are they more primitive. Mosses are the cousins of other land plants.

So when reading a phylogeny, it is important to keep three things in mind:

1. Evolution produces a pattern of relationships among lineages that is tree-like, not ladder-like.

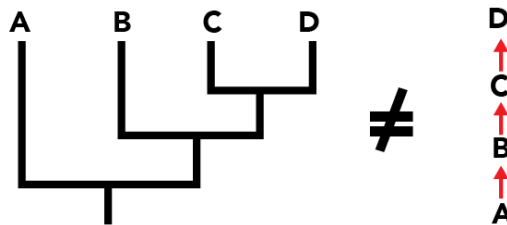

2. Just because we tend to read phylogenies from left to right, there is no correlation with level of "advancement."

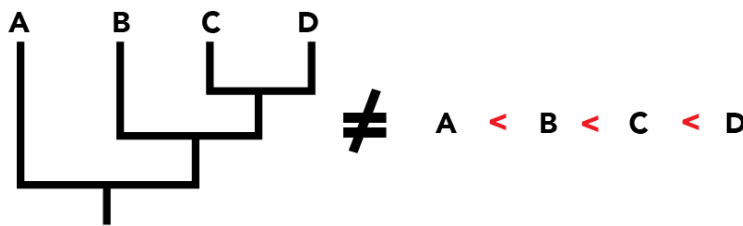

3. For any speciation event on a phylogeny, the choice of which lineage goes to the right and which goes to the left is arbitrary. The following phylogenies are equivalent:

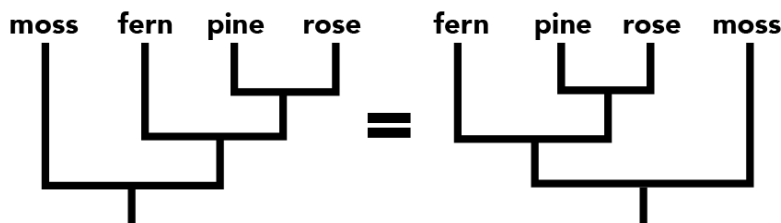



Biologists often put the clade they are most interested in (whether that is bats, bedbugs, or bacteria) on the right side of the phylogeny.

### Misconceptions about humans

The points described above cause the most problems when it comes to human evolution. The phylogeny of living species most closely related to us looks like this:

It is important to remember that:

1. Humans did not evolve from chimpanzees. Humans and chimpanzees are evolutionary cousins and share a recent common ancestor that was neither chimpanzee nor human.
2. Humans are not “higher” or “more evolved” than other living lineages. Since our lineages split, humans and chimpanzees have each evolved traits unique to their own lineages.

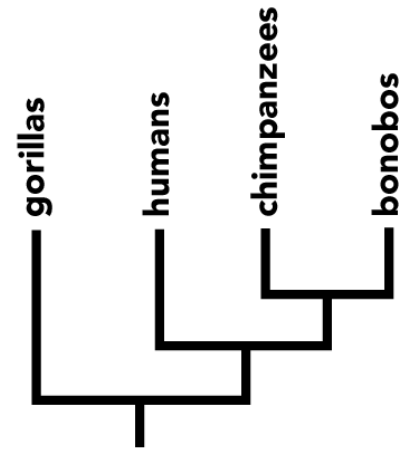



## Building the tree

Like family trees, phylogenetic trees represent patterns of ancestry. However, while families have the opportunity to record their own history as it happens, evolutionary lineages do not — species in nature do not come with pieces of paper showing their family histories. Instead, biologists must reconstruct those histories by collecting and analyzing evidence, which they use to form a hypothesis about how the organisms are related — a phylogeny.

To build a phylogenetic tree such as the one shown below, biologists collect data about the characters of each organism they are interested in. Characters are heritable traits that can be compared across organisms, such as physical characteristics (morphology), genetic sequences, and behavioral traits.

In order to construct the vertebrate phylogeny, we begin by examining representatives of each lineage to learn about their basic morphology, whether or not the lineage has vertebrae, a bony skeleton, four limbs, an amniotic egg, etc.

### Using shared derived characters

Our goal is to find evidence that will help us group organisms into less and less inclusive clades. Specifically, we are interested in shared derived characters. A shared character is one that two lineages have in common, and a derived character is one that evolved in the lineage leading up to a clade and that sets members of that clade apart from other individuals.

Shared derived characters can be used to group organisms into clades. For example, amphibians, turtles, lizards, snakes, crocodiles, birds and mammals all have, or historically had, four limbs. If you look at a modern snake you might not see obvious limbs, but fossils show that ancient snakes did have limbs, and some modern snakes actually do retain rudimentary limbs. Four limbs is a shared derived character inherited from a common ancestor that helps set apart this particular clade of vertebrates.

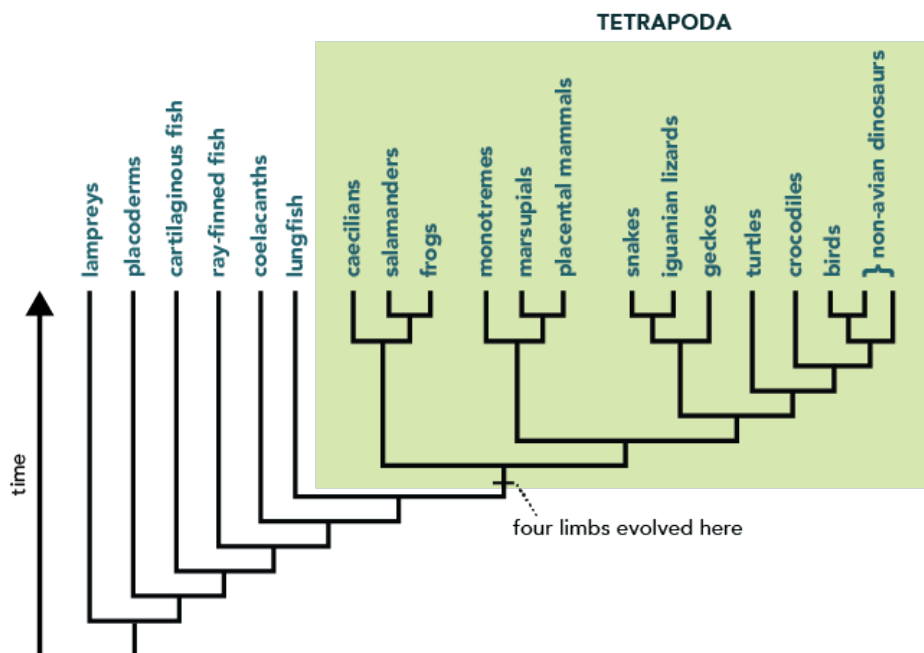

Tree adapted from Irisarri, I., Baurain, D., Brinkmann, H., Delsuc, F., Sire, J.-Y., Kupfer, A., ... and Philippe, H., 2017. Phylotranscriptomic consolidation of the jawed vertebrate timetree. *Nat Ecol Evol* 1, 1370–1378. <https://doi.org/10.1038/s41559-017-0240-5>

However, the presence of four limbs is not useful for determining relationships within the clade in green above, since all lineages in the clade have that character. To determine the relationships in that clade, we would need to examine other characters that vary across the lineages in the clade.



## Homologies and analogies

Since a phylogenetic tree is a hypothesis about evolutionary relationships, we want to use characters that are reliable indicators of common ancestry to build that tree. We use homologous characters — characters in different organisms that are similar because they were inherited from a common ancestor that also had that character. An example of homologous characters is the four limbs of tetrapods. Birds, bats, mice, and crocodiles all have four limbs. Sharks and bony fish do not. The ancestor of tetrapods evolved four limbs, and its descendants have inherited that feature — so the presence of four limbs is a homology.

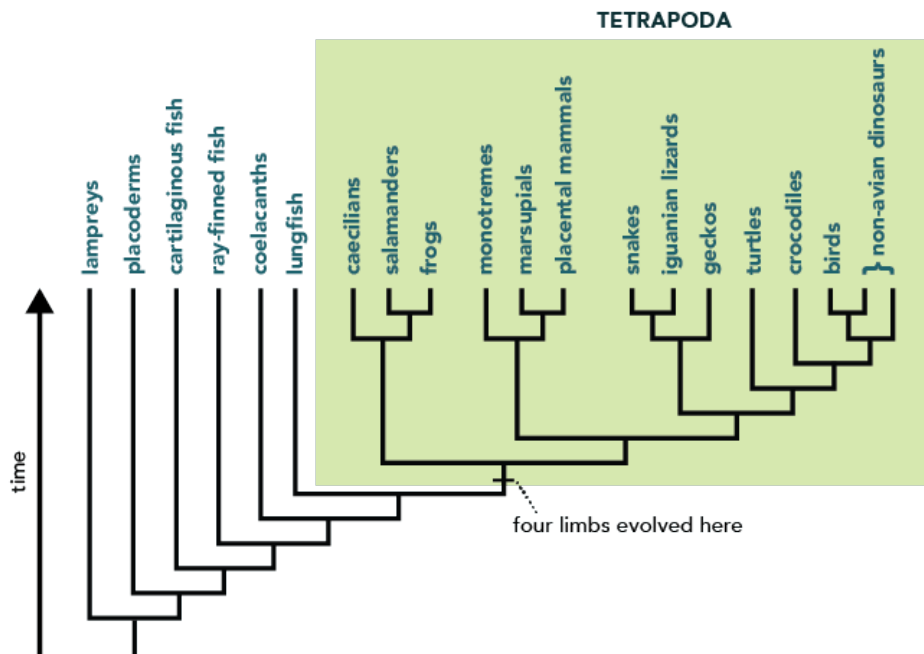

Tree adapted from Irisarri, I., Baurain, D., Brinkmann, H., Delsuc, F., Sire, J.-Y., Kupfer, A., ... and Philippe, H., 2017. Phylotranscriptomic consolidation of the jawed vertebrate timetree. *Nat Ecol Evol* 1, 1370–1378. <https://doi.org/10.1038/s41559-017-0240-5>

Not all characters are homologies. For example, birds and bats both have wings, while mice and crocodiles do not. Does that mean that birds and bats are more closely related to one another than to mice and crocodiles? No. When we examine bird wings and bat wings closely, we see that there are some major differences.

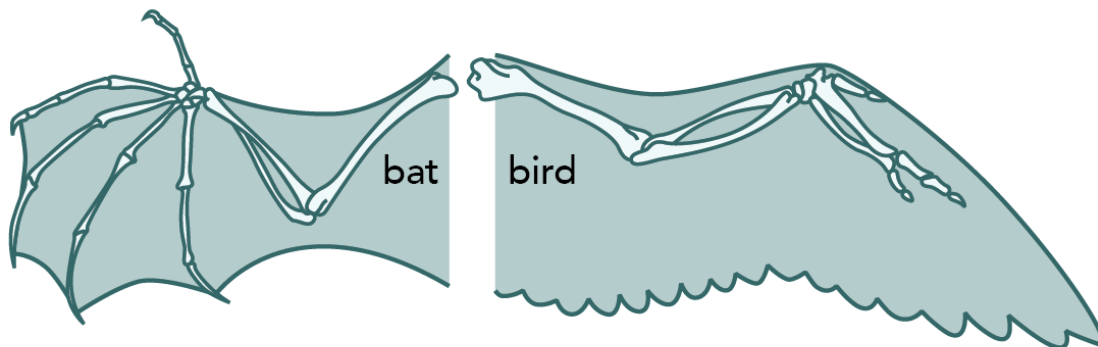

Bat wings consist of flaps of skin stretched between the bones of the fingers and arm. Bird wings consist of feathers extending all along the arm. These structural dissimilarities suggest that bird wings and bat wings were not inherited from a common ancestor with wings. This idea is illustrated by the phylogeny below, which is based on a large number of other characters.

## Evolution 101: The history of life: looking at the patterns

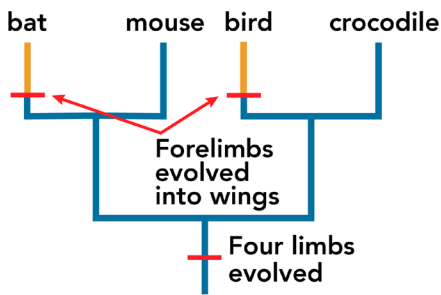

Bird and bat wings are analogous — that is, they have separate evolutionary origins, but are superficially similar because they have both experienced natural selection that shaped them to play a key role in flight. Analogies are the result of convergent evolution.

Interestingly, though bird and bat wings are analogous as wings, as forelimbs they are homologous. Birds and bats did not inherit wings from a common ancestor with wings, but they did inherit forelimbs from a common ancestor with forelimbs.



## Using the tree for classification

Biologists use phylogenetic trees for many purposes, including:

- Testing hypotheses about evolution
- Learning about the characteristics of extinct species and ancestral lineages
- Classifying organisms

Using phylogenies as a basis for classification is a relatively new development in biology.

Most of us are accustomed to the Linnaean system of classification that assigns every organism a kingdom, phylum, class, order, family, genus, and species, which, among other possibilities, has the handy mnemonic **King Philip Came Over For Good Soup**. This system was created long before scientists understood that organisms evolved. Because the Linnaean system is not based on evolution, most biologists are switching to a classification system that reflects the organisms' evolutionary history.

This phylogenetic classification system names only clades — groups of organisms that are all descended from a common ancestor. As an example, we can look more closely at reptiles and birds.

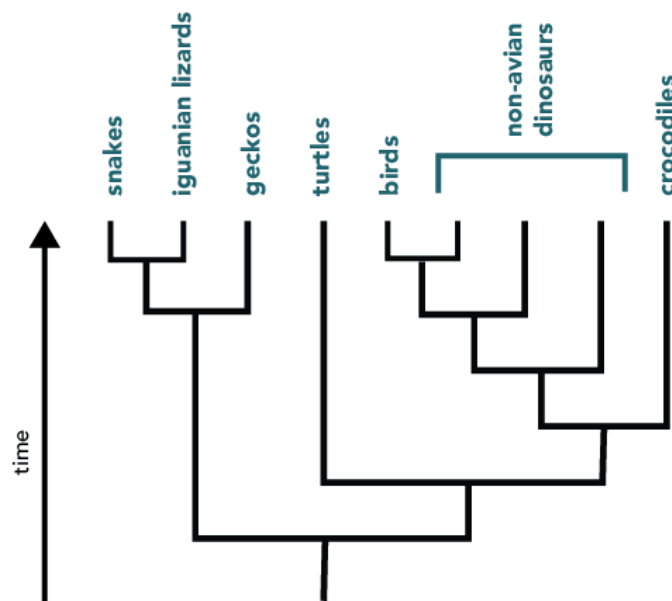

Tree adapted from Irisarri, I., Baurain, D., Brinkmann, H., Delsuc, F., Sire, J.-Y., Kupfer, A., ... and Philippe, H., 2017. Phylotranscriptomic consolidation of the jawed vertebrate timetree. *Nat Ecol Evol* 1, 1370–1378. <https://doi.org/10.1038/s41559-017-0240-5>

## Evolution 101: The history of life: looking at the patterns



Under a system of phylogenetic classification, we could name any clade on this tree. For example, the Testudines, Squamata, Archosauria, and Crocodylomorpha all form clades.

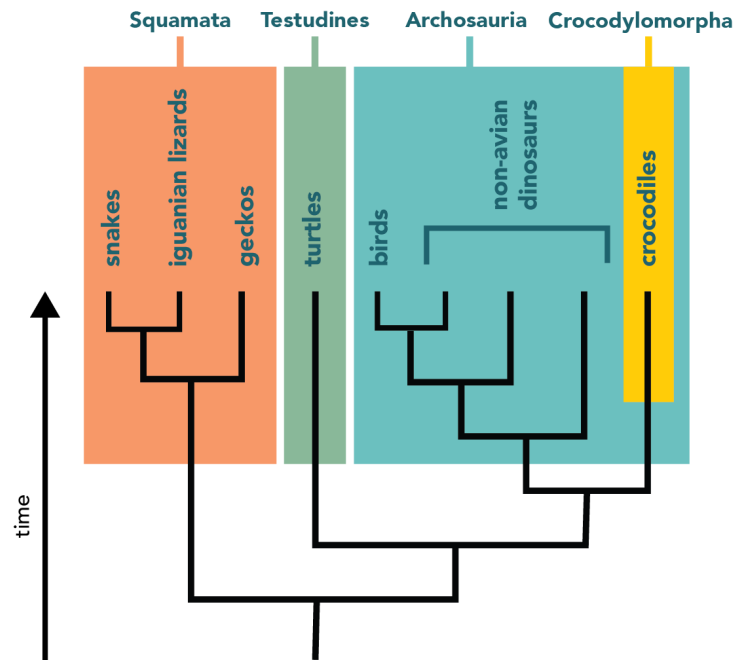

However, the reptiles do not form a clade, as shown in the cladogram. That means that either “reptile” is not a valid phylogenetic grouping or we have to start thinking of birds as reptiles.

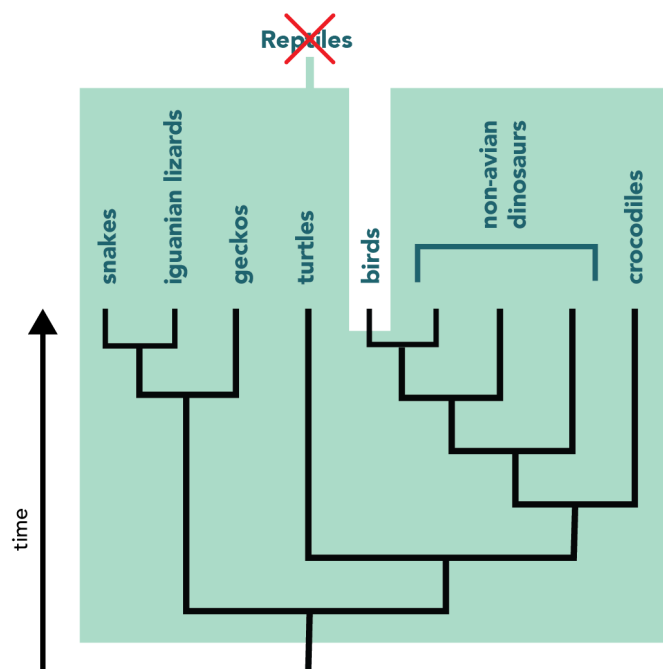

## Evolution 101: The history of life: looking at the patterns



Another cool thing about phylogenetic classification is that it means that dinosaurs are not entirely extinct. Birds are, in fact, dinosaurs (part of the clade Dinosauria). It's pretty neat to think that you could learn something about T. rex by studying birds!

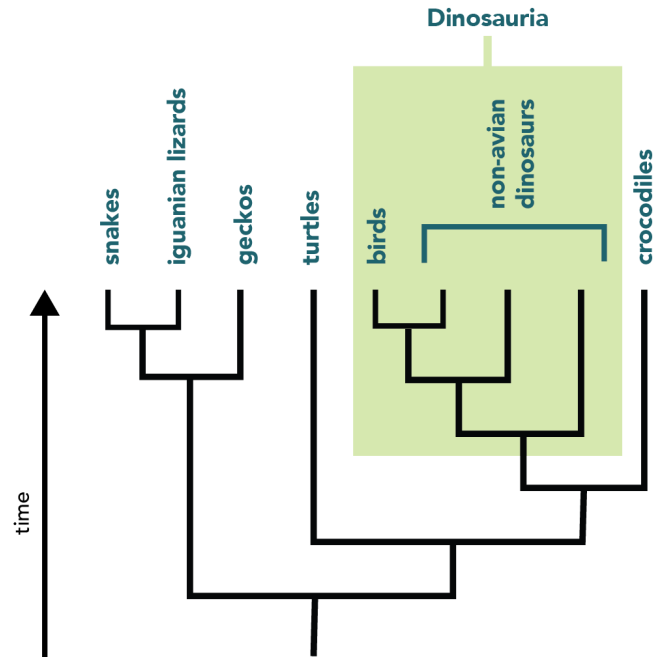



## Adding time to the tree

If you wanted to squeeze the 3.8 billion years of the history of life on Earth into a single minute, you would have to wait about 50 seconds for multicellular life to evolve, another four seconds for vertebrates to invade the land, and another four seconds for flowers to evolve — and only in the last 0.002 seconds would “modern” humans arise.

Biologists often represent time on phylogenies by drawing the branch lengths in proportion to the amount of time that has passed since that lineage arose. If the tree of life were drawn in this way, it would have a very long trunk indeed before it reached the first plant and animal branches.

The following phylogeny represents vertebrate evolution — just a small clade on the tree of life. The lengths of the branches have been adjusted to show when lineages split and went extinct.

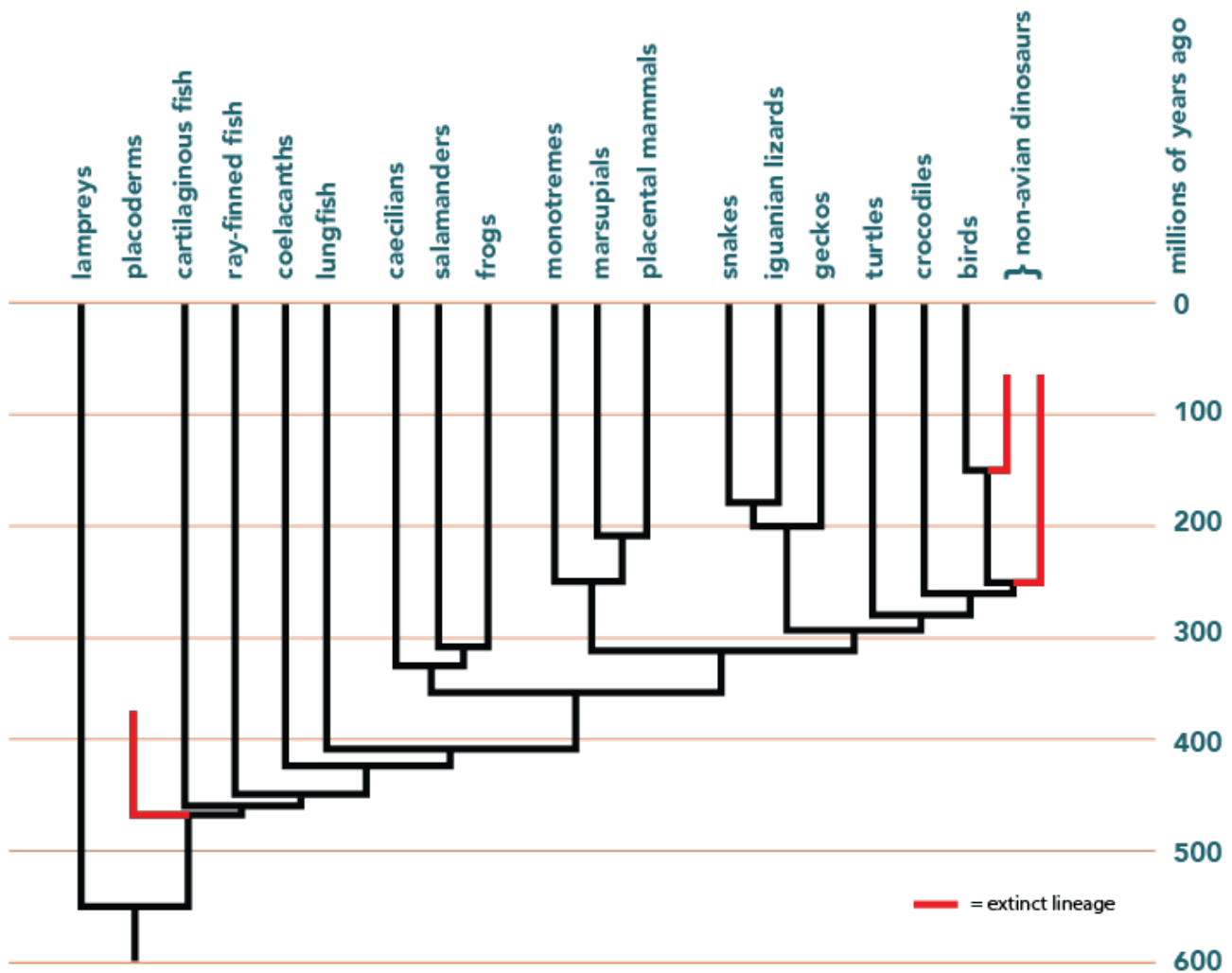

Tree adapted from Irisarri, I., Baurain, D., Brinkmann, H., Delsuc, F., Sire, J.-Y., Kupfer, A., ... and Philippe, H., 2017. Phylotranscriptomic consolidation of the jawed vertebrate timetree. *Nat Ecol Evol* 1, 1370–1378. <https://doi.org/10.1038/s41559-017-0240-5>



### How we know what happened when

Life began 3.8 billion years ago, and insects diversified 290 million years ago, but the human and chimpanzee lineages diverged only five million years ago. How have scientists figured out the dates of long past evolutionary events? Here are some of the methods and evidence that scientists use to put dates on events:

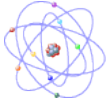

1. Radiometric dating relies on half-life decay of radioactive elements to allow scientists to date rocks and materials directly.

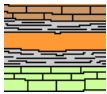

2. Stratigraphy provides a sequence of events from which relative dates can be extrapolated.



3. Molecular clocks allow scientists to use the amount of genetic divergence between organisms to extrapolate backwards to estimate dates.



## Important events in the history of life

A timeline can provide additional information about life's history not visible on an evolutionary tree. These include major geologic events, climate changes, radiations of organisms into new habitats, changes in ecosystems, changes in continental positions, and widespread extinctions. Explore the timeline below to review some of the important events in life's history.

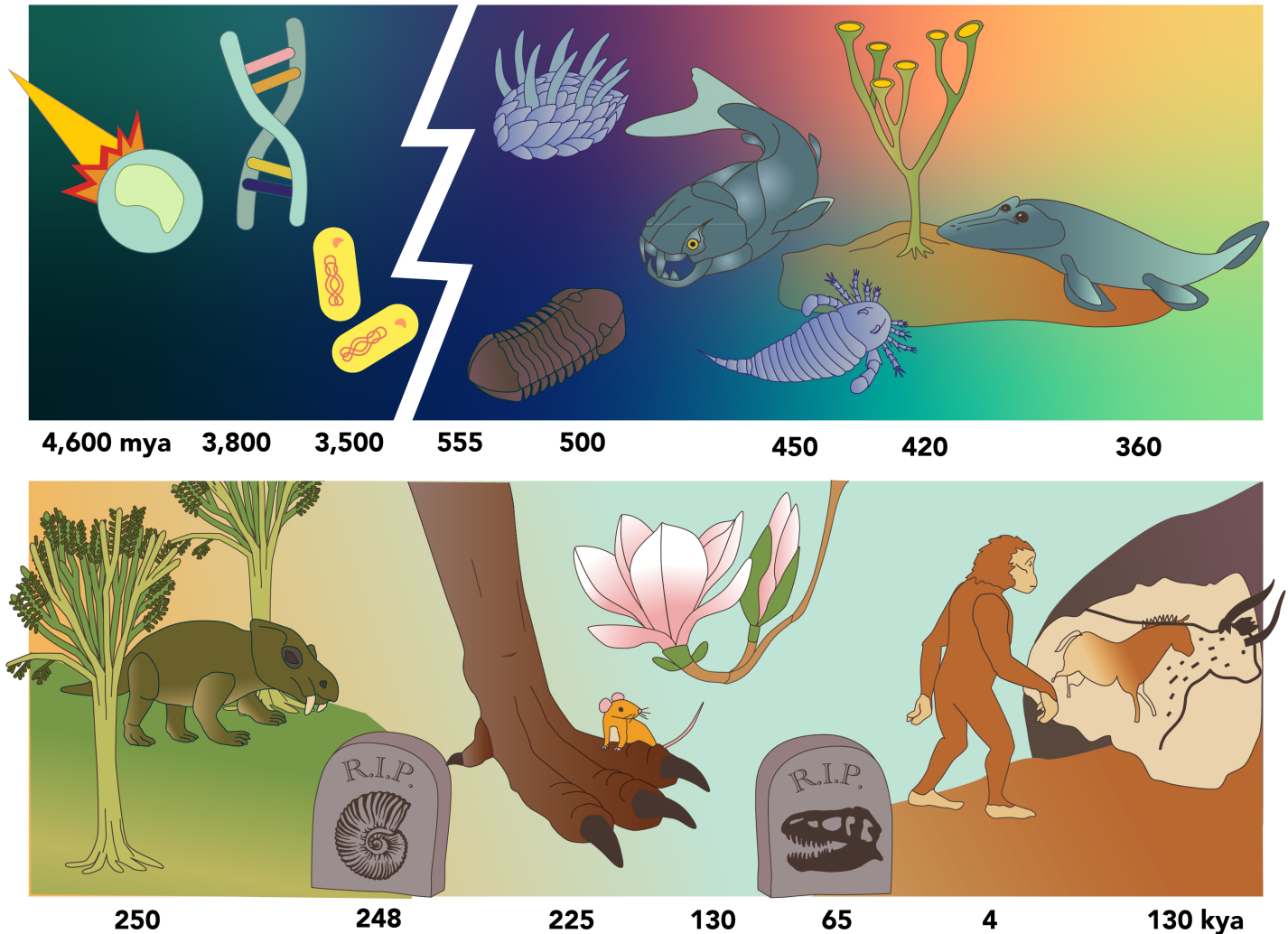

Years ago	Event
130,000	Anatomically modern humans evolve. Seventy thousand years later, their descendents create cave paintings — early expressions of consciousness.
4 million	In Africa, an early hominid, affectionately named “Lucy” by scientists, lives. The ice ages begin, and many large mammals go extinct.
65 million	A massive asteroid hits the Yucatan Peninsula, and ammonites and non-avian dinosaurs go extinct. Birds and mammals are among the survivors.
130 million	As the continents drift toward their present positions, the earliest flowers evolve, and dinosaurs dominate the landscape. In the sea, bony fish diversify.
225 million	Dinosaurs and mammals evolve. Pangea has begun to break apart.

## Evolution 101: The history of life: looking at the patterns



<b>248 million</b>	Over 90% of marine life and 70% of terrestrial life go extinct during the Earth's largest mass extinction. Ammonites are among the survivors.
<b>250 million</b>	The supercontinent called Pangea forms. Conifer-like forests, reptiles, and synapsids (the ancestors of mammals) are common.
<b>360 million</b>	Four-limbed vertebrates move onto the land as seed plants and large forests appear. The Earth's oceans support vast reef systems.
<b>420 million</b>	Land plants evolve, drastically changing Earth's landscape and creating new habitats.
<b>450 million</b>	Arthropods move onto the land. Their descendants evolve into scorpions, spiders, mites, and millipedes.
<b>500 million</b>	Fish-like vertebrates evolve. Invertebrates, such as trilobites, crinoids, brachiopods, and cephalopods, are common in the oceans.
<b>555 million</b>	Multi-cellular marine organisms are common. The diverse assortment of life includes bizarre-looking animals like Wiwaxia.
<b>3.5 billion</b>	Unicellular life evolves. Photosynthetic bacteria begin to release oxygen into the atmosphere.
<b>3.8 billion</b>	Replicating molecules (the precursors of DNA) form.
<b>4.6 billion</b>	The Earth forms and is bombarded by meteorites and comets.



### Mechanisms: the processes of evolution

Evolution is the process by which modern organisms have descended from ancient ancestors. Evolution is responsible for both the remarkable similarities we see across all life and the amazing diversity of that life — but exactly how does it work? Here, we'll find out.

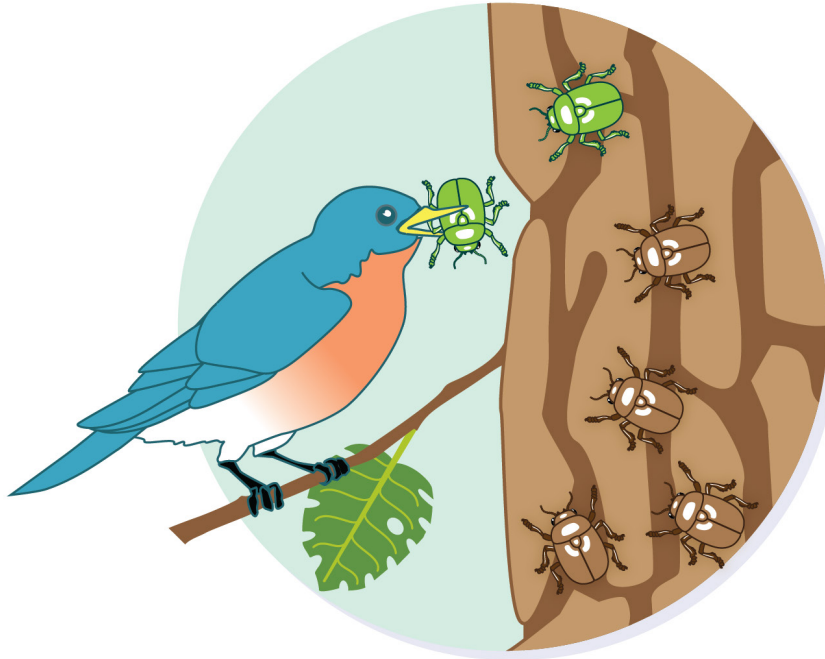



## Descent with modification

We've defined evolution as descent with modification from a common ancestor, but exactly what has been modified? Evolution occurs when there is a change in the heritable information passed from one generation to the next. Typically, we think of biological evolution as changes in gene frequency within a population over time – if, say, birds with genes that produce wide beaks went from being rare to being common over multiple generations. But biological evolution also includes changes in DNA that does not code for genes and changes in heritable information not encoded in DNA at all. In all of these cases, the modifications are heritable and can be passed on to the next generation – which is what really matters in evolution: long term change. Here, we'll focus on changes in genes and other genetic elements (e.g., in non-coding DNA) as they relate to evolution.

Compare these two examples of change in beetle populations. Which one is an example of evolution?

### 1. Beetles on a diet

Imagine the population experiences many years of drought in which there are few plants that the beetles can eat.



All the beetles have the same chances of survival and reproduction, but because of food restrictions, the beetles in later generations are smaller than the pre-drought generations of beetles.

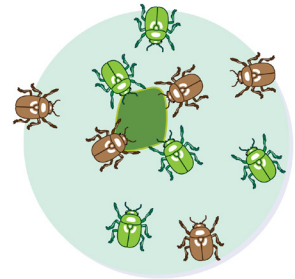

### 2. Beetles of a different color

Most of the beetles in the population (say 90%) have a gene for green coloration and a few of them (10%) have a gene that makes them brown.

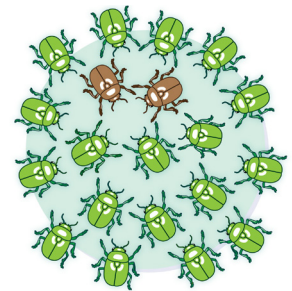

Several generations later, things have changed: brown beetles are more common and make up 70% of the population.

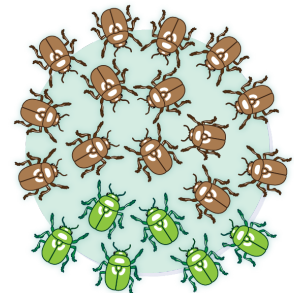

Which example illustrates descent with modification? The difference in size in example 1 came about because of environmental influences – the low food supply – not because of a change in heritable information. Therefore,

---

## Evolution 101: Mechanisms: the processes of evolution

---



example 1 is not evolution. Because the small body size in this population was not genetically determined, it is temporary: if the beetles' food supply is restored, this generation of small-bodied beetles will produce normal size offspring.

The shift in color frequency in example 2 is definitely evolution: these two generations of the same population are genetically different. There has been a change in heritable information, and this shift will be passed down to the next generation (possibly with further changes introduced). But how did it happen?



## Mechanisms of change

Each of these four processes is a basic mechanism of evolutionary change and is illustrated with an example of gene frequency change in a beetle population with brown and green individuals.

**Mutation:** A mutation could cause beetle parents with genes for bright green coloration to have offspring with a gene for brown coloration. That would make genes for brown coloration more frequent in the population than they were before the mutation.

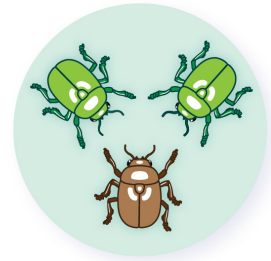

**Migration:** Some individuals from a population of brown beetles might have moved into a population of green beetles. That would make genes for brown coloration more frequent in the green beetle population than they were before the brown beetles migrated into it. In evolutionary biology, migration is also called “gene flow.”

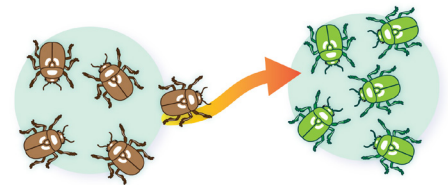

**Genetic drift:** In one generation, brown beetles happened to have many offspring survive to reproduce. In the same generation, a number of green beetles were killed randomly when someone stepped on them and had no offspring. The next generation had more brown beetles than the previous generation — but just by chance. These chance changes from generation to generation are known as genetic drift.



**Natural selection:** Imagine that green beetles are easier for birds to spot (and hence, eat). Thus, brown beetles are a little more likely to survive to produce offspring. They pass their genes for brown coloration on to their offspring. So in the next generation, brown beetles are more common than they were in the previous generation.

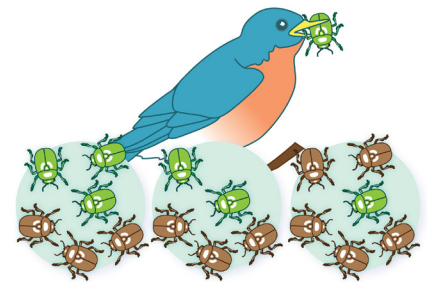

All of these mechanisms can cause changes in the frequencies of genes and other genetic elements in populations, and so all of them are mechanisms of evolutionary change. However, natural selection and genetic drift can only change the frequency of different genes and genetic elements (e.g., making wide beaks or green beetles more or less common); they cannot introduce fundamentally new traits to a population.

So, what are the sources of new genetic variants – i.e., genetic variation?



### Genetic variation

Without genetic variation, some key mechanisms of evolutionary change like natural selection and genetic drift cannot operate.

There are three primary sources of new genetic variation:

1. **Mutations** are changes in the information contained in genetic material. (For most of life, this means a change in the sequence of DNA.) A single mutation can have a large effect, but in many cases, evolutionary change is based on the accumulation of many mutations with small effects.
2. **Gene flow** is any movement of genetic material from one population to another (e.g., through migration) and is an important source of genetic variation.
3. **Sex** can introduce new gene combinations into a population. This genetic shuffling is another important source of genetic variation.

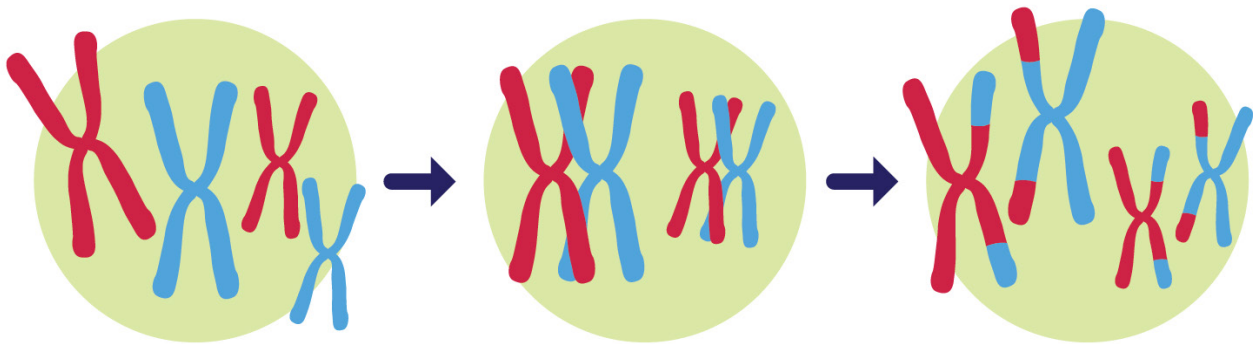

Genetic shuffling is a source of variation.



### Mutations

Mutations are changes in the information contained in genetic material. For most of life, this means a change in the sequence of DNA, the hereditary material of life. An organism's DNA affects how it looks, how it behaves, its physiology — all aspects of its life. So a change in an organism's DNA can cause changes in all aspects of its life.

#### Mutations are random

Mutations can be beneficial, neutral, or harmful for the organism, but mutations do not “try” to supply what the organism “needs.” In this respect, mutations are random — whether a particular mutation happens or not is unrelated to how useful that mutation would be.

#### Not all mutations matter to evolution

Since all cells in our body contain DNA, there are lots of places for mutations to occur; however, not all mutations matter for evolution. Somatic mutations occur in non-reproductive cells and so won't be passed on to offspring.

For example, the yellow color on half of a petal on this red tulip was caused by a somatic mutation. The seeds of the tulip do not carry the mutation. Cancer is also caused by somatic mutations that cause a particular cell lineage (e.g., in the breast or brain) to multiply out of control. Such mutations affect the individual carrying them but are not passed directly on to offspring.



Photo from Wikipedia, by LepoRello under CC BY-SA 3.0.

The only mutations that matter for the evolution of life's diversity are those that can be passed on to offspring. These occur in reproductive cells like eggs and sperm and are called germline mutations.



### The effects of mutations

A single germline mutation can have a range of effects:

#### 1. No effect or neutral effect

Some mutations don't have any noticeable effect on the organism. This can happen in many situations: perhaps the mutation occurs in a stretch of DNA with no function, or perhaps the mutation occurs in a protein-coding region, but does not affect the amino acid sequence of the protein. Other mutations have a noticeable effect, but one that doesn't seem to help or hurt. For example, a single mutation caused this cat's ears to curl backwards slightly, a trait that doesn't seem to affect its health.

#### 2. Detrimental effect

Some mutations harm an organism's ability to survive and reproduce. For example, in humans, Marfan syndrome is caused by a mutation affecting a protein that forms part of connective tissue, leading to heart problems and other health challenges. Detrimental mutations known as lethals disrupt DNA critical to survival and cause the death of the organism.

#### 3. Beneficial effect

Other mutations are helpful to the organisms that carry them. For example, DDT resistance in insects is sometimes caused by a single mutation. While resistant insects might be downer for us, they are undoubtedly helpful for bugs trying to survive on pesticide-laden crops.

According to popular culture, it seems that mutations mainly cause either cancer or superpowers. Of course, the cancer is true enough. But in the real world, beneficial mutations are rare. Most mutations have no effect or a detrimental effect. And major evolutionary change (e.g., the "superpower" of flight in bats!) generally involves the accumulation of many, many mutations over many, many generations.

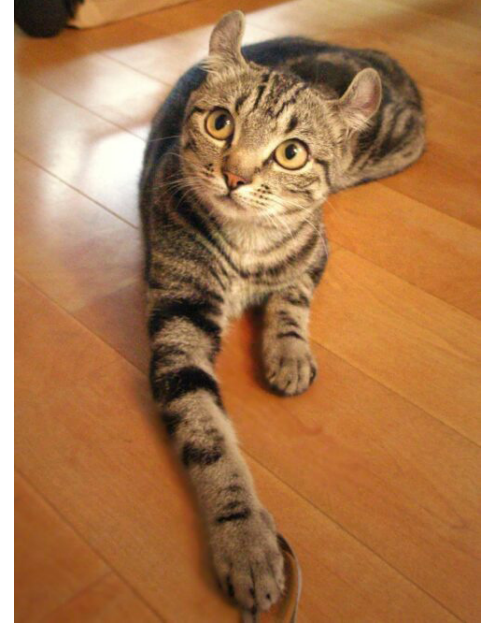

Image courtesy of Tanakawho's Flickr, under the Creative Commons Attribution 2.0 Generic license.



## The causes of mutations

Mutations happen for several reasons.

### 1. DNA spontaneously breaks down or is not copied accurately

Most of the mutations that we think matter to evolution are “naturally-occurring.” For example, when a cell divides, it makes a copy of its DNA — and sometimes the copy is not quite perfect. That small difference from the original DNA sequence is a mutation. Spontaneous breakdown of DNA can also cause mutations.

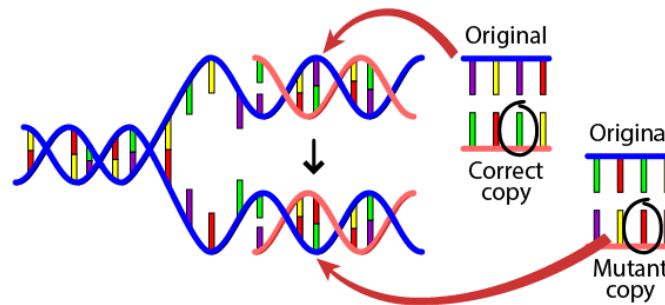

### 2. External influences can cause mutations

Mutations can also be caused by exposure to specific chemicals or radiation that cause the DNA to break down. Cells do have mechanisms to repair damaged or altered DNA molecules, but they aren't perfect. Whatever the cause, mutations occur any time a cell ends up carrying a DNA sequence slightly different than the original.



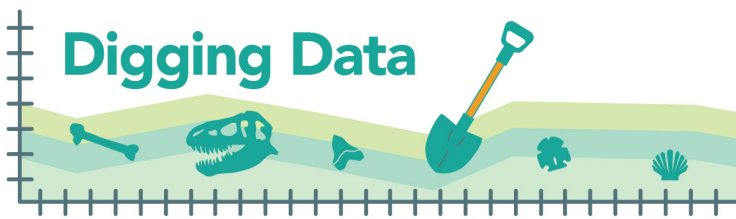

## The causes of mutation

Mutations – changes in the genetic sequence of DNA or RNA – are the raw material for evolution. Natural selection, genetic drift, and other evolutionary processes act on genetic variation – and that genetic variation starts with mutation. Even if a genetic variant is introduced to a population through migration, ultimately, that variant got its start as a mutation. So understanding where, when, why, and how often mutations occur is key in understanding how evolution happens. Today, quick and inexpensive DNA sequencing means biologists can take a closer look than ever before at the process of mutation. What they are learning is sometimes surprising.

In humans, each baby has around 70 brand new or “de novo” mutations. De novo mutations occur in the reproductive cells of parents and are passed on to the child. Evidence suggests that most de novo mutations in a child come from the sperm that helped create that child, and relatively few mutations come from the egg. Biologists thought this made sense. In humans, beginning at puberty, the cells that produce sperm divide (and copy their DNA) throughout adulthood, leading to vast numbers of sperm. In contrast, in a person with ovaries, all the DNA copying leading up to egg production is completed before that person is even born.<sup>[1]</sup> The cells that produce sperm just go through many more cycles of DNA replication and cell division than do the cells that produce eggs.<sup>[2]</sup> If most mutations happen because a cell makes an error when it copies its DNA, producing a new DNA strand that differs slightly in sequence compared to the original, then we’d expect sperm to be the source of most new mutations. All those cell divisions in the cells that eventually lead to sperm provide many opportunities for copying mistakes to occur.

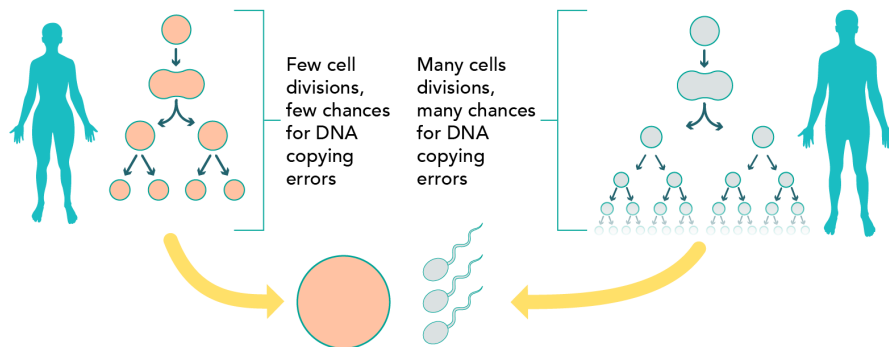

Biologists Felix Wu, Alva Strand, Laura Cox, Carole Ober, Jeffrey Wall, Priya Moorjani, and Molly Przeworski work at different universities and research centers, but they all wanted to know, **is it really the case that most new mutations in humans are caused by copying errors when cells divide?** Some evidence had already suggested that copying errors are not the whole story when it comes to heritable mutations.

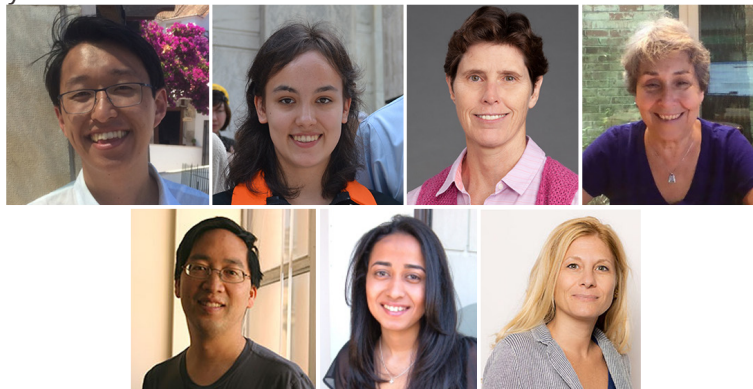

The research team. Top row: Felix Wu, Alva Strand, Laura Cox, Carole Ober. Bottom row: Jeff Wall, Priya Moorjani, Molly Przeworski. Photos reproduced with permission from the individuals.

## Hypothesis

The research team set out to test the hypothesis that **most de novo mutations occur because of copying errors**. They looked at what percent of new mutations in a baby come from DNA carried by sperm, as opposed to from DNA carried by the egg; we'll call this "sperm bias" in new mutations. If new mutations mostly come from copying errors, then the number of mutations contributed by eggs should not be much affected by the age of the person contributing the egg (since, in primates, all the DNA copying that leads up to egg production occurs before that future parent is even born). However, the number of mutations contributed by the sperm *should* increase with the age of the genetic father (since DNA copying and cell divisions leading to sperm are ongoing from puberty throughout adulthood). Overall, this means that **if the hypothesis were true, we'd expect to see that species with younger genetic fathers (and a shorter interval between puberty and fatherhood) should have less sperm bias in new mutations than species with older genetic fathers (and a longer interval between puberty and fatherhood)**.

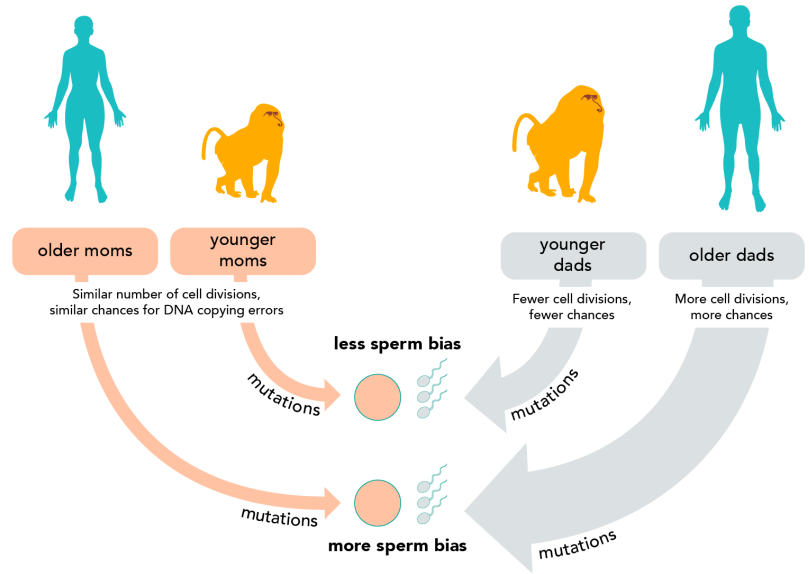

## Data

The team decided to compare mutations in humans to mutations in olive baboons (*Papio anubis*). The two primates are closely related, but male baboons go through puberty at age 6 and reproduce at age 10 on average, while humans that produce sperm typically start puberty around age 13 and don't reproduce until age 32 on average. This means that the cells that produce baboon sperm go through about 4 years' worth of DNA replication and cell division before a sperm leads to offspring, while the cells that produce human sperm go through about 19 years' worth of DNA replication and cell division before a sperm leads to a child! That's a big difference, providing lots more opportunity for mutations caused by DNA copying errors to accumulate in the sperm-producing cells of humans compared to those of baboons. To get data on mutations, the team sequenced the genomes of three generations of three different human families (26 people total) and three generations of two baboon families (29 baboons total).

They focused on tallying up selected spots in the genome where the DNA sequences of the parents were the same, but their child's genetic sequence was different from that of both parents.<sup>[3]</sup> The only way to explain this outcome is if one of the parents contributed a brand new mutation to the child. Then the researchers used additional sequence information to determine which parent (mother or father) had contributed each mutation.<sup>[4]</sup> This is what they found:

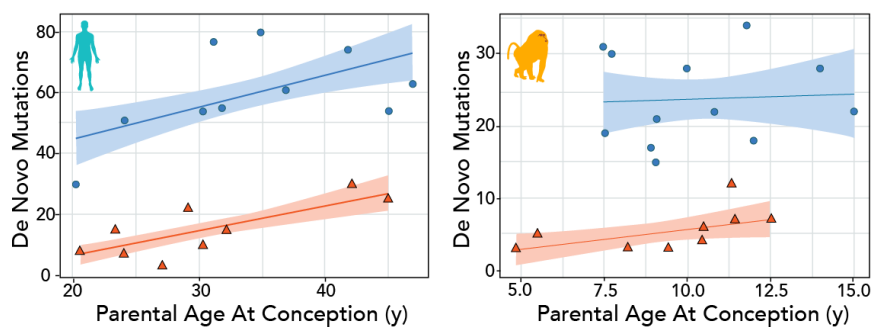

In these graphs, each offspring in which new mutations were identified is represented by a circle and a triangle.



The circle indicates the number of mutations contributed by the sperm and the triangle indicates the number contributed by the egg. The lines show the overall relationship between age at conception (on the x-axis) and mutations (on the y-axis). The shading around these regression lines indicates the 95% confidence intervals.

Right away, we can observe a few things. First, the blue circles are always positioned above the red triangles, indicating that sperm contribute more mutations than do eggs. That's just as we'd expect based on other research. Second, in humans, older genetic parents do seem to pass on more mutations to offspring, as shown by the upward slope of the regression lines. In baboons, the mothers' age is associated with more mutations (the line slopes upwards), while the regression line for fathers is nearly flat – suggesting that older fathers *don't* contribute more mutations. This result goes against previous findings about mutations and age. But if you look at the male baboon data closely, you'll notice that the blue confidence interval is wider than the others. This means that the data vary a lot, making it hard to detect patterns without a really large sample. So it is possible that baboon fathers, like humans, do pass on more mutations to their offspring as they age, but there were not enough data in this experiment to detect the pattern.

The researchers used their data to calculate the proportion of all new mutations that came from the father (i.e., were paternal), as shown in the graph below. The vertical lines represent the 95% confidence intervals for each point. A chi-squared test showed that the two values are not significantly different ( $p = 0.91$ ). **Even though the baboons were much younger than the humans when they reproduced (and the cells that produce their sperm have been through many fewer rounds of DNA replication and cell division), the degree of sperm bias in the two species is similar! That does not match the expectation generated by the hypothesis that most new mutations come from copying errors.**

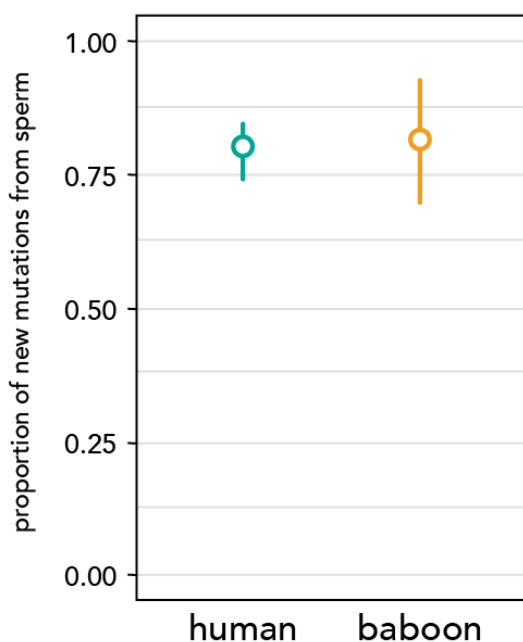

If not copying errors, what is the source of the new mutations that primate offspring are born with? The research team suspects that sloppy DNA fixes play a role. DNA, including the DNA within sperm and eggs, is easily damaged. And when it is, a cell does its best to put the strand back together perfectly. But sometimes it mistakenly substitutes one genetic letter for another, generating a mutation. The idea that errors in DNA repair are an important source of mutations that matter for evolution fits with many lines of evidence – including the evidence described here that the number of new mutations increases with the age of both genetic parents. After all, we might expect the chances of DNA damage and sloppy repair to be fairly constant over time, so as the cells that lead to eggs and sperm get older, we'd expect them to accumulate more mutations, which are passed on to daughter cells and ultimately, to the eggs and sperm themselves. But exactly how important this process is, as well as how it might vary between the sexes and across species, has yet to be worked out. Furthermore, the idea that DNA damage and poor repair are the main source of *de novo* mutations does not help us understand why we observe sperm bias in the first place. As our genetic techniques advance further, biologists like Felix, Molly, and their colleagues will have even more data to home in on the processes that lead to mutations, tracing genetic variation back to its original source.

## Stepping into science

The research team was led by Felix Wu, a graduate student at Columbia University in New York City, and Molly Przeworski, a professor there. Molly did grow up in a large city and spent most of her leisure time reading novels. She was utterly uninterested in math or science—her least favorite topic in school was biology. But a great teacher drew her into math in college and after a series of false starts, she discovered genetics and evolutionary biology.

Footnotes:

[1] The initial stages of oogenesis (egg production) occur during fetal development before birth. During this stage, the DNA that will wind up in eggs



is copied in preparation for cell division – and it is during this stage that mutations caused by copying errors might occur. However, this process is then halted before any cell division takes place. The final cell divisions that produce eggs will actually occur during the reproductive years, during the menstrual cycle and fertilization – but no DNA replication occurs at this time.

[2]Technically, we are focused on DNA replication in the stem cells that produce eggs and sperm. The stem cells that eventually lead to sperm go through more cycles of DNA replication than do the stem cells that produce eggs, providing more opportunities for DNA replication errors to occur.

[3]The researchers focused on single nucleotide polymorphisms (SNPs) – single base pair differences. To be extra certain that they were detecting brand new mutations, they focused on genome positions where the child was a heterozygote and both parents were homozygotes. They then checked their data using several different methods.

[4]This is trickier to do than it might sound. After all, primates are diploid; if a primate offspring shows up with a mutation on one chromosome out of a pair, how do we tell which chromosome, the one from the egg or the one from the sperm, contributed that mutation? Figuring it out requires looking at nearby positions on the chromosome – i.e., figuring out the genetic background on which the mutation most likely occurred. If the new mutation is located on a chromosome near a signature sequence present only in the genetic father, we know that person must have contributed the mutation.



### Gene flow

Gene flow — also called migration — is any movement of individuals, and/or the genetic material they carry, from one population to another. Gene flow includes lots of different kinds of events, such as pollen being blown to a new destination or people moving to new cities or countries. If genetic variants are carried to a population where they previously did not exist, gene flow can be an important source of genetic variation. In the graphic below, a beetle carries the gene version for brown coloration from one population to another.

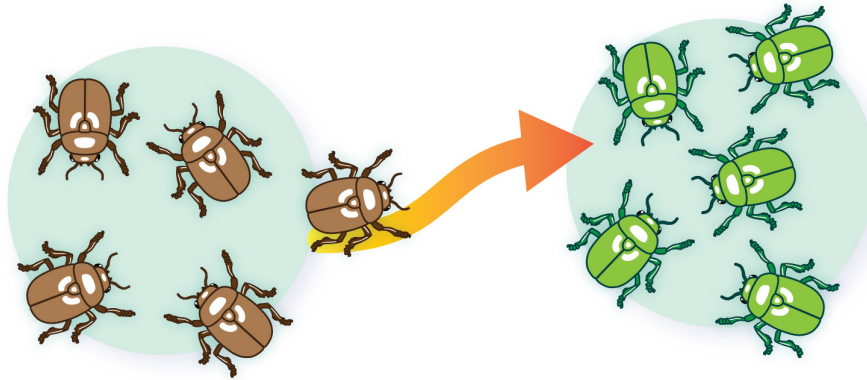

The genetic variation in modern human populations has been critically shaped by gene flow. For example, by sequencing ancient DNA, researchers have reconstructed the entire Neanderthal genome – and they’ve found that many snippets of these archaic sequences live on in modern humans. It’s clear that ancient humans and Neanderthals interbred, and that this gene flow introduced new genetic variation to the human population. Furthermore, this ancient gene flow seems to affect who we are today. Neanderthal gene versions have been linked to immune functions, metabolic functions (e.g., affecting one’s risk of developing diabetes), and even skin color.



### Sex and genetic shuffling

Sex can introduce new gene combinations into a population and is an important source of genetic variation.

You probably know from experience that siblings are not genetically identical to their parents or to each other (except, of course, for identical twins). That's because when organisms reproduce sexually, some genetic "shuffling" occurs, bringing together new combinations of genes. For example, you might have bushy eyebrows and a big nose since your mom had genes associated with bushy eyebrows and your dad had genes associated with a big nose. These combinations can be good, bad, or neutral. If your spouse is wild about the bushy eyebrows/ big nose combination, you were lucky and hit on a winning combination!

This shuffling is important for evolution because it can introduce new combinations of genes every generation. For example, in a particular population, plants with reddish flowers and plants with longer more tubular flowers might each do fine on their own – but if sex and genetic shuffling produced a plant with both traits (red tubular flowers), the combination might attract a new pollinator (hummingbirds) and alter the evolutionary trajectory of the lineage. Of course, sex and genetic shuffling can also break up good combinations of genes and form bad ones.

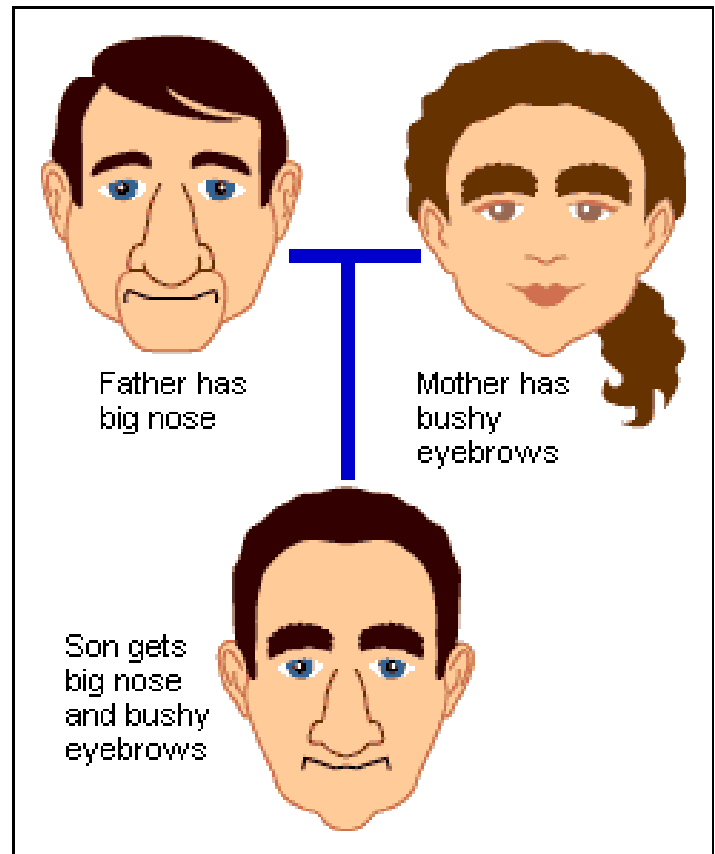



## Development

Development is the process through which a fertilized egg, the earliest stage of an embryo, becomes an adult organism. Throughout development, an organism's genotype is expressed as a phenotype, exposing genes and the genetic elements that control their expression to the action of natural selection. Genetic variation in genes affecting development seems to have played an important role in evolution.

### Explaining major evolutionary change

Changes in the genes controlling development can have major effects on the morphology of the adult organism. Because these effects are so significant, scientists suspect that changes in the expression of developmental genes have helped bring about large-scale evolutionary transformations. Developmental changes, as well as new genes, may help explain, for example, how some hoofed mammals evolved into ocean-dwellers, how water plants invaded the land, and how small, armored invertebrates evolved wings.



Mutations in the genes that control fruit fly development can cause major morphology changes, such as two pairs of wings instead of one.

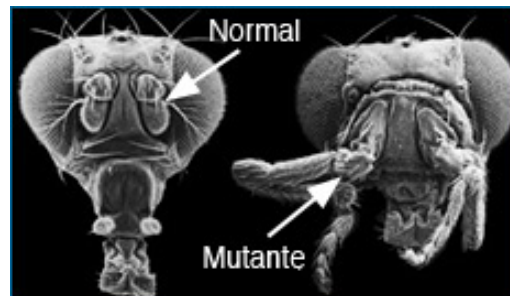

Another developmental gene mutation can cause fruit flies to have legs where the antennae normally are, as shown in the fly on the right. Fruit fly images courtesy of Jean-Michel Muratet, Syndicat National des Ophtalmologistes de France (SNOF).

Developmental processes may also constrain the sorts of phenotypes that genetic variation can lead to, and so might prevent certain characters from evolving in certain lineages. For example, development may help explain why there are no truly six-fingered tetrapods among living species.

### Learning about evolutionary history

In addition, an organism's development may contain clues about its history that biologists can use to help build evolutionary trees. For example, the relationship between sand dollars and an unusual group of sea urchins called cassiduloids was once a conundrum. The two groups strongly resemble each other and so seemed closely related; however, sand dollars have a complicated jaw structure (called the lantern) that cassiduloids lack. Could they really be close relatives with such a big difference? The answer, it turns out, was yes. Scientists discovered that developing cassiduloid embryos pass through a stage where they have a lantern; it was merely lost in the adult stage through evolution. Sand dollars and cassiduloids have more in common than one might think from their adult forms alone, and they do occupy the same branch of the sea urchin family tree after all.

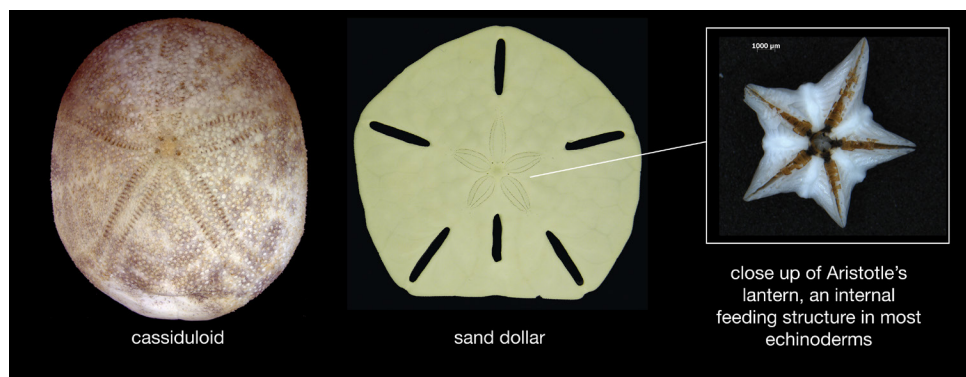

All photos courtesy of Camilla Souto, PhD.



### Genetic drift

Genetic drift is one of the basic mechanisms of evolution.

In each generation, some individuals may, just by chance, leave behind a few more descendants (and genes, of course!) than other individuals. The genes and other genetic elements of the next generation will be those of the “lucky” individuals, not necessarily the healthier or “better” individuals. That, in a nutshell, is genetic drift. It happens to ALL populations — there’s no avoiding the vagaries of chance.



Earlier we used this hypothetical cartoon. Genetic drift affects the genetic makeup of the population, but unlike natural selection, through an entirely random process. So although genetic drift is a mechanism of evolution, it doesn’t work to produce adaptations.



## Natural Selection

Natural selection is one of the basic mechanisms of evolution, along with mutation, migration, and genetic drift.

Darwin's grand idea of evolution by natural selection is relatively simple but often misunderstood. To see how it works, imagine a population of beetles:

### 1. There is variation in traits.

For example, some beetles are green and some are brown.

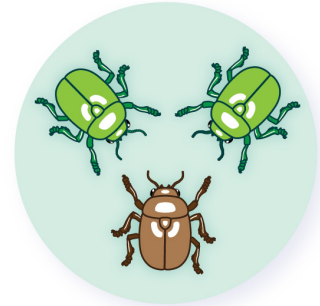

### 2. There is differential reproduction.

Since the environment can't support unlimited population growth, not all individuals get to reproduce to their full potential. In this example, green beetles tend to get eaten by birds and survive to reproduce less often than brown beetles do.

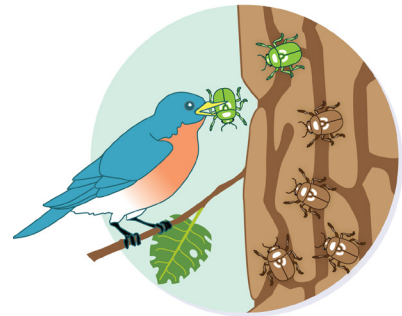

### 3. There is heredity.

The surviving beetles (more of which are brown) have offspring of the same color because this trait has a genetic basis.

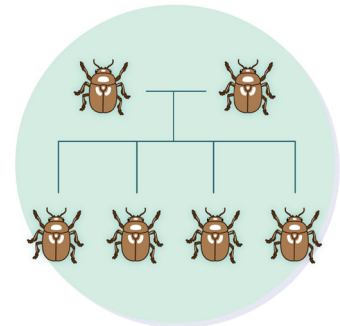

**4. End result:** The more advantageous trait, brown coloration, which allows the beetle to have more offspring, becomes more common in the population.

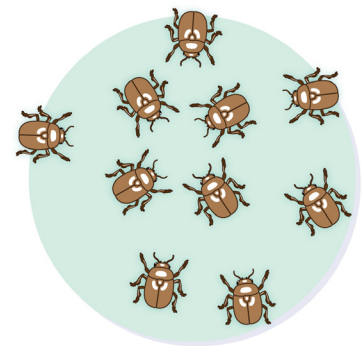

If this process continues, eventually, all individuals in the population will be brown. If you have variation, differential reproduction, and heredity, you will have evolution by natural selection as an outcome. It is as simple as that.



### Natural selection at work

Scientists have worked out many examples of natural selection, one of the basic mechanisms of evolution.

Natural selection can produce impressive adaptations that help organisms survive and reproduce. A few examples are shown below.



Orchids fool wasps into "mating" with them. Orchid and wasp image courtesy of Colin Bower.



Katydids have camouflage to look like leaves. Image © Greg Neise, GE Neise Digital Communication.



Non-venomous king snakes mimic venomous coral snakes. Images courtesy of Neurotoxin.

Behavior can also be shaped by natural selection. Behaviors such as birds' mating rituals, bees' wobble dance, and humans' capacity to learn language have genetic components and are subject to natural selection. The male blue-footed booby, for example, exaggerates his foot movements, an adaptation that helps him attract a mate.

In some cases, we can directly observe natural selection occurring. Very convincing data show that the shape of finches' beaks on the Galapagos Islands has tracked weather patterns: after droughts, the finch population has deeper, stronger beaks that let them eat tougher seeds.

In other cases, human activity has led to environmental changes that have caused populations to evolve through natural selection. A striking example is that of the peppered moth, which may have either light or dark coloration. During the Industrial Revolution, when air pollution darkened tree trunks, dark-colored forms were favored because they were better camouflaged and so became more common. When pollution was later reduced, light-colored forms rebounded and became more common. Natural selection triggered by human activity can often be observed and documented.



Blue-footed booby image courtesy of Ian Skipworth.



## Evolutionary fitness

Evolutionary biologists use the word fitness to describe how good a particular genotype is at leaving offspring in the next generation relative to other genotypes. So if brown beetles consistently leave more offspring than green beetles because of their color, you'd say that the brown beetles had a higher fitness. In evolution, fitness is about success at surviving and reproducing, not about exercise and strength.

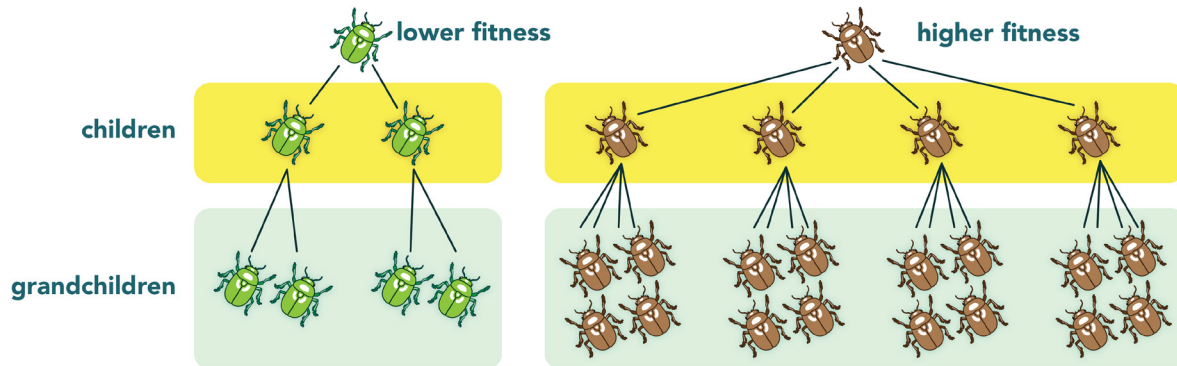

Of course, fitness is a relative thing. A genotype's fitness depends on the environment in which the organism lives. The fittest genotype during an ice age, for example, is probably not the fittest genotype once the ice age is over.

Fitness is a handy concept because it lumps everything that matters to natural selection (survival, mate-finding, reproduction) into one idea. The fittest individual is not necessarily the strongest, fastest, or biggest. A genotype's fitness includes its ability to survive, find a mate, produce offspring — and ultimately leave its genes in the next generation.



A penguin and its two offspring. Photo by Jeff Abbas © California Academy of Sciences.



A stomatopod (or mantis shrimp) with thousands of small, light pink eggs. Photo by Roy Caldwell.

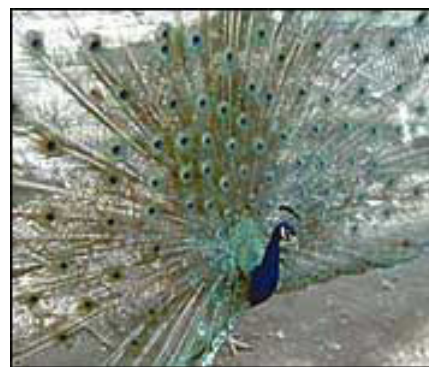

A male peacock with its tail feathers displayed. 1Photo courtesy of Rock Maple Farm.

Caring for your offspring (above left), producing thousands of young — many of whom won't survive (above right) — and sporting fancy feathers that attract females (left) are a burden to the health and survival of the parent. These strategies do, however, increase fitness because they help the parents get more of their offspring into the next generation.

We tend to think of natural selection acting on survival ability — but, as the concept of fitness shows, that's only half the story. When natural selection acts on mate-finding and reproductive behavior, biologists call it sexual selection.



## Sexual Selection

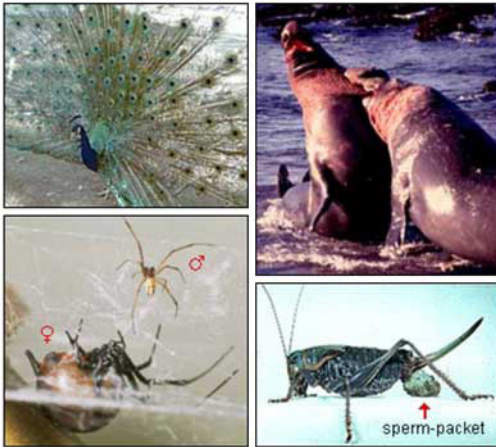

Peacock image courtesy of Rock Maple Farm; Elephant seals image courtesy of Craig's Homepage; Mormon cricket image courtesy of Grasshoppers of Wyoming and the West; Redback spiders image courtesy of Andrew Mason, University of Toronto at Scarborough

Sexual selection is a “special case” of natural selection. Sexual selection acts on an organism’s ability to obtain (often by any means necessary!) or successfully copulate with a mate.

Sexual selection has shaped many extreme adaptations that help organisms find mates: peacocks (top left) maintain elaborate tails, elephant seals (top right) fight over territories, fruit flies perform dances, and some species deliver persuasive gifts. After all, what female Mormon cricket (bottom right) could resist the gift of a juicy sperm-packet? Going to even more extreme lengths, the male redback spider (bottom left) literally flings itself into the jaws of death in order to mate successfully.

Sexual selection is even powerful enough to produce features that are harmful to the individual’s survival. For example, extravagant and colorful tail feathers or fins are likely to attract predators as well as interested members of the opposite sex.

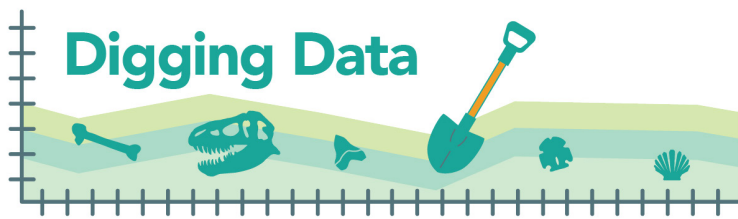

## Sexual selection

The venomous female redback spider – also known as the Australian black widow – poses a danger to humans ... and to male redback spiders, which are often eaten by their mates. Males seem to go out of their way to make this happen, flipping themselves over and presenting their abdomens to the female while mating. This behavior might at first seem like one that selection would act against. After all, how could risking one's life be adaptive? Remember that evolutionary fitness is about getting genes into the next generation, not just survival. **Perhaps this extreme behavior is favored by sexual selection because it gives males a fitness boost. But what advantage could it offer?** Biologist Maydianne Andrade made observations and designed a set of experiments to find out



Maydianne Andrade, evolutionary biologist and Professor and Vice Dean at the University of Toronto Scarborough

## Background

Male redback spiders deliver their sperm to females using specialized mouthparts. If the female is hungry, she will eat the male during the mating process. In the wild, this happens about 65% of the time. Females often mate with more than one male and can store sperm (sometimes for years!) to use later. Females produce multiple egg sacs throughout their lives, each of which can contain hundreds of eggs. Different eggs in a single egg sac may be fertilized by sperm from different fathers.



Female redback spider with egg sac at right. Much smaller male (circled) at left. Photo courtesy of Wikimedia.

## Hypotheses

There are several explanations that could lead to the evolution of males' risky mating behavior:

**1. The nutrients provided by eating the male are passed on to the eggs/offspring.** In this scenario, sexual selection would favor males that offer themselves up as a meal because those males would leave behind more or perhaps more robust eggs that are more likely to hatch into live spiderlings.



**2. Eating one's mate decreases the likelihood that a female will mate again with another male.** In this scenario, sexual selection would favor the risky behavior because males that allow themselves to be eaten would prevent later matings and, thus, would father more of a female's brood.

**3. Males that are eaten mate for longer and so fertilize more of a female's eggs.** Perhaps eating a mate takes time, or perhaps females simply allow mates that offer up their abdomens to mate longer. In either case, evolution would favor the risky behavior if it allows a male to father more of the female's offspring than do males that do not offer up a snack.

Maydianne made observations and carried out experiments to test each of these hypotheses.

## Data

**Hypothesis 1 – Does a female's "snack" give a boost to her eggs?** In captive redbacks in the lab, Maydianne compared the number of eggs in and weight of egg sacs from matings where the male was eaten to those from matings in which he was not:

Factor	Cannibalistic matings			Noncannibalistic matings			Mann-Whitney (P)
	N*	95% CL	Median	N*	95% CL	Median	
Egg sac mass (mg)	9	170 to 230	198	13	155 to 198	179	0.082
Number of eggs per sac	9	223 to 361	256	13	199 to 321	249	0.526

The 95% CL (confidence level) is the range within which the true value is likely to fall (i.e., in 100 cases with similar data, the true value is within this range in 95 of those cases). The Mann-Whitney test looks at whether two samples are likely to come from sources with the same median. The p value of this test indicates the probability that the two samples come from sources with the same median (i.e. are \*not\* different).

There is a very slight trend towards more eggs and heavier egg sacs resulting from cannibalistic matings (as seen by comparing the pink highlighted medians), but this difference is not significant (blue highlighted box). This contradicts hypothesis 1.

**Hypothesis 2 – Did eating a mate decrease the odds that a female would mate again with a different male?** In the lab, Maydianne observed females' first and subsequent matings and collected the following data:

Female behavior	% of time she mated again
Ate first mate	33% (3 out of 9 matings)
Did not eat first	96% (22 out of 23 matings)

Apparently, skipping breakfast (not eating one's first mate) leaves female redbacks interested in a snack (one's second mate)! These data support hypothesis 2.



**Hypothesis 3 – Does self-sacrifice pay off with paternity?** Maydianne also observed and timed matings in the lab, and then determined the paternity of the eggs that the female ultimately produced. Maydianne focused on the second male to mate with a female. She thought that a male allowing himself to be eaten might pay off in terms of paternity, particularly if he were able to mate for longer if cannibalized. She observed that cannibalized second males mate for much longer (a median of 25 minutes) than second males that are not eaten (and mate for a median of just 11 minutes). Here are data from 10 matings:

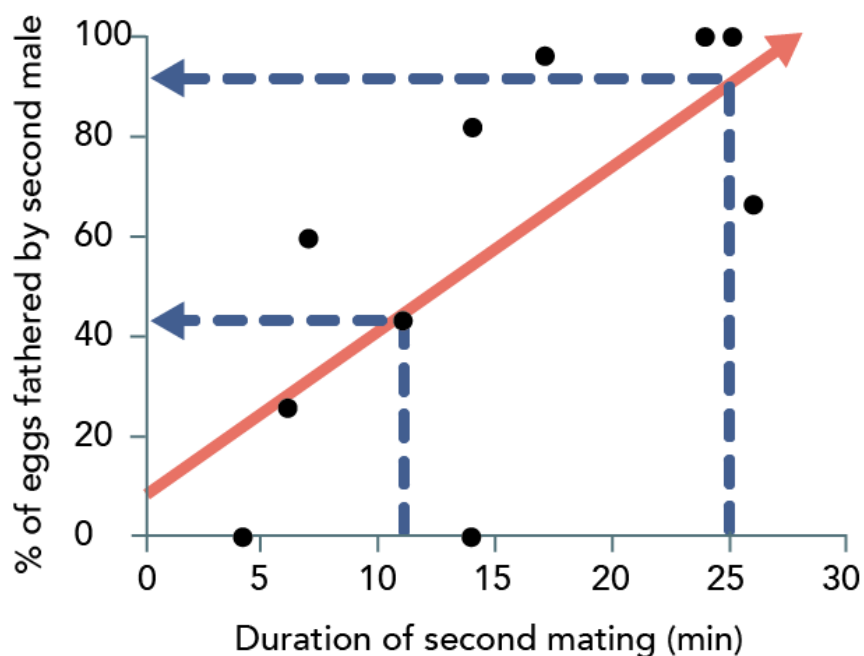

For each mating, she plotted a point (black dot) representing how long the second mating took (x-axis) and the fraction of the eggs in the sac fathered by that second male (y-axis). The data are pretty clear: longer mating is associated with more paternity. This is shown by the upward slope of the regression line (red arrow). The dotted lines and blue arrows show how much a second male can improve his fitness by fathering more eggs if he is eaten and mates for 25 min, as opposed to surviving and mating just 11 minutes. Based on these data, we'd expect self-sacrificers to father 92% of eggs versus just 45% for survivors. These data support hypothesis 3.

Sexual selection seems to be shaping male redback spiders' self-sacrificial mating behavior, not through the nutrition provided by eating one's mate, but through its effect on fertilization rate and female behavior. But note the small sample sizes. More data might make us more confident in this interpretation.

## Stepping into science

Maydianne started doing research as an undergraduate. She got interested in studying invertebrates, since she could mimic their natural environments in the lab. She was particularly curious to learn what males contribute to their mates and offspring – so when her Master's advisor told her about the strange behavior of male redback spiders, she was intrigued. And when she realized she'd be able to escape the Canadian winter and visit sunny Australia, she was sold!



## Why is sexual selection so powerful?

It's clear why sexual selection is so powerful when you consider what happens to the genes of an individual who lives to a ripe old age but never produced offspring: no offspring means no genes in the next generation, which means that all those genes for living to a ripe old age don't get passed on to anyone! That individual's fitness is zero. Compare that to an individual who does not live very long, but leaves behind children...



## Selection is a two-way street

Sexual selection usually works in two ways, although in some cases we do see sex role reversals:

- **Male competition**

Males compete for access to females, the amount of time spent mating with females, and even whose sperm gets to fertilize her eggs. For example, male damselflies scrub rival sperm out of the female reproductive tract when mating.

- **Female choice**

Females choose which males to mate with, how long to mate, and even whose sperm will fertilize her eggs. Some females can eject sperm from an undesirable mate.



## Artificial selection

Long before Darwin and Wallace, people were using selection to change the features of plants and animals. Farmers and breeders allowed only the plants and animals with desirable characteristics to reproduce, causing the evolution of farm stock. This process is called artificial selection because people (instead of nature) select which organisms get to reproduce.

As shown below, farmers have cultivated many crops from wild mustard by artificially selecting for certain attributes.

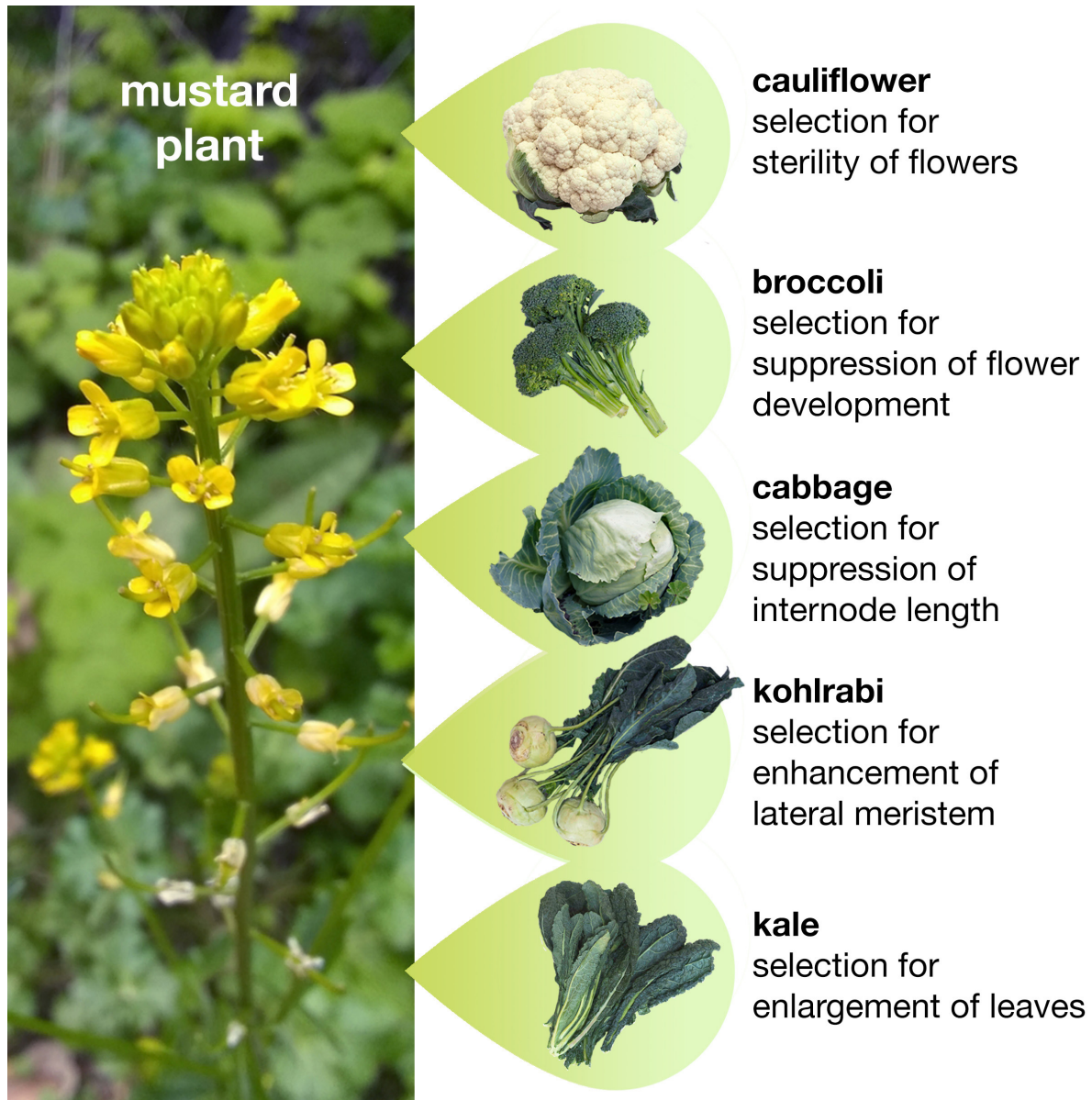

Mustard photo courtesy of Pat Holroyd, all other brassica courtesy of Helina Chin.

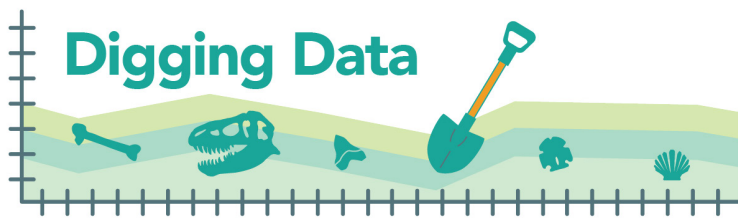

## Artificial selection

Just as humans developed crop plants and domesticated animals from wild ancestors, we also used artificial selection to create distinct varieties and breeds of these species. Domestic dogs evolved from ancient, now-extinct wolf ancestors tens of thousands of years ago<sup>[1]</sup> – and then, over the last 200 years, humans further selected subsets of dogs, creating Great Danes, Chihuahuas, and the full gamut of more than 450 breeds.



Chihuahua (left) and Chesapeake Bay Retriever (right). Photos provided by Dayna Dreger.

During the process of developing different breeds, the focus was on traits. We didn't know which genes bestowed, for example, swimming skills or rat-catching ability; we just knew that we wanted dogs that were better at pulling fishing nets (leading to Chesapeake Bay Retrievers and Portuguese Water Dogs) and clearing out pests (leading to the Rat Terrier). In recent decades, scientists have been able to track down some of the genes that we unwittingly selected for in different breeds. Elaine Ostrander, a biologist at the National Institutes of Health, is one of these scientists. She and her team study dogs in order to answer basic questions about genetics that have implications for human health.



The team of scientists behind the study: Elaine Ostrander, Jaemin Kim, Dayna Dreger (top row), Jocelyn Plassais, Brian Davis, and Heidi Parker (bottom row). Falina Williams, also an author on the study, is not pictured. Photos provided by Ostrander lab.



In one study, Elaine and a team that included Jaemin Kim, Falina Williams, Dayna Dreger, Jocelyn Plassais, Brian Davis, and Heidi Parker focused on sport hunting dogs, which are an active group of breeds that perform many different jobs. This group includes spaniels, retrievers, and hunting dogs. The team identified 59 genes that seem to have been the targets of recent selection in these dogs.<sup>[2]</sup> A particular variant (i.e., an allele) of one of these genes – called *ROBO1* – was common in the most agile breeds. These athletic breeds were unusually likely to have an A base at a location in the gene where other breeds were more likely to have a C base. **The initial data suggested that *ROBO1* was one of the genes that humans unwittingly affected when they artificially selected breeds for different sorts of athletic abilities, but the team wanted more evidence.**

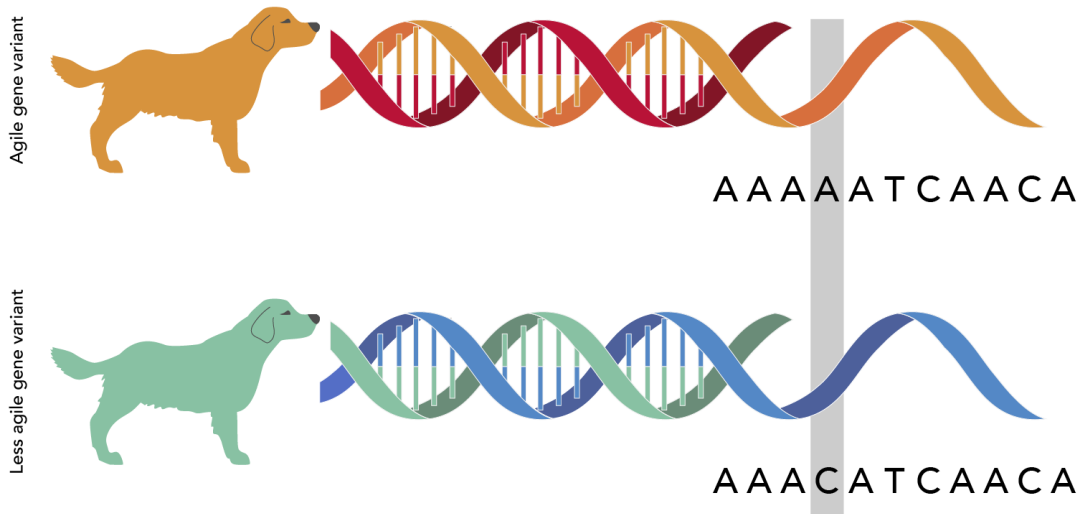

## Background

Broadly, agility is the ability to move quickly and easily, but for dogs, it can have a more specific meaning. Agility is a sport in which a person directs a dog to run through a complex obstacle course. For a dog to perform well in agility competitions, it must have both the athletic skills to make it through the course quickly and the mental skills to respond nimbly to commands and assess obstacles.



Australian Shepherd in an agility competition. Photo by Ron Armstrong from Helena, MT, USA, CC BY 2.0 via Wikimedia Commons

*ROBO1* may be related to those mental skills. From studies of humans, we know that *ROBO1* is involved with brain development. Different versions of *ROBO1* affect how the brain works and learns. For example, having a certain version of *ROBO1* seems to contribute to dyslexia, a condition where people have trouble reading.



## Hypothesis

The team had identified the A version of *ROBO1* based on a relatively small sample of breeds. This led to the hypothesis that **the A version of the gene was favored by artificial selection in breeds in which humans desired traits that lead to high agility. If this hypothesis were true across breeds, then we'd expect the A gene version to be more common in more agile breeds** – that is, we'd expect to observe a positive relationship between the frequency of the A gene version and breed agility.

## Data

To assess agility, the team used records of which breeds were entered in agility competitions and which breeds actually won agility titles. For each breed, they calculated the number of titles won per dog of that breed entered in competition. They then divided breeds into eight groups according to how likely each breed was to win agility titles:

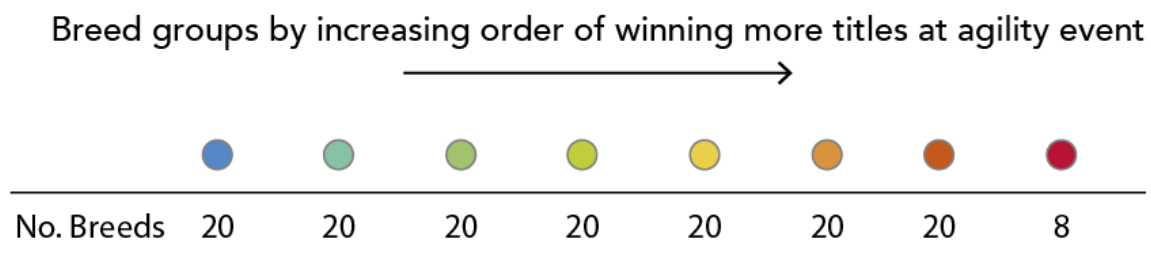

Top performers (such as Border Collies and Pumis, both herding dogs) were in the red group. Breeds that never or very rarely won agility competitions (like the Greyhound and Anatolian Shepherd) were in the blue group.

To figure out how common the A gene version of *ROBO1* was in these different groups of dogs, the team turned to a database of dog DNA sequences. They found *ROBO1* data for 1243 dogs of breeds in one of the eight breed groups.



Greyhound. Photo provided by Dayna Dreger.

These were not dogs that had necessarily competed in agility trials themselves; they were just dogs that were members of the same breeds as competitors. For each of the eight breed groups, the team calculated how common the A gene version of *ROBO1* was compared to other gene versions. Here is what they found:

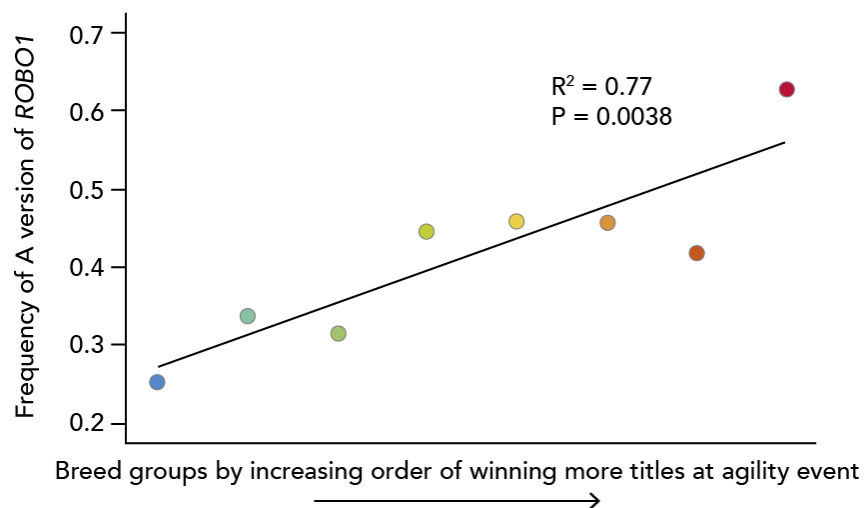

On this graph, the x-axis orders the eight breed groups from least likely to win agility titles (far left) to most likely (far right). The y-axis shows how common the A gene version is in that group. So, for example, a frequency of 0.4 means that the A gene version was found in 40% of the sequences from dogs of that group. **There is a clear, strong relationship between tendency to win agility titles and frequency of the A gene version:** the regression line slopes upwards, and this is significant ( $p = 0.0038$ ).  $R^2$  indicates how well the frequency of different gene versions is explained by the breed group. An  $R^2$  of 0 would indicate that breed group cannot predict the frequency of the A gene version at all. An  $R^2$  of 1 would indicate that one can precisely predict the frequency of the A gene version based on breed group. In this case, the  $R^2$  value of 0.77 indicates that 77% of the variation in the frequency of the A gene version is explained by breed group. **These findings further support the hypothesis that the A version of *ROBO1* was under strong artificial selection by humans in breeds for which humans desired traits that lead to strong agility.** Now researchers can build on this hypothesis to learn exactly how the A version of *ROBO1* impacts dogs that carry it, why the A gene version was favored in some breeds but not others, and importantly, how this might be related to athletic performance and other traits in humans.

## Stepping into science

When Elaine Ostrander learned about genetics as a sophomore in high school, she knew she'd found her calling. She wanted to be a scientist. But she didn't have any role models around her: no parent or friends were scientists. So Elaine forged her own path. Throughout high school and college, she worked all sorts of jobs – tutor, waitress, janitor, dishwasher – so she could get the training she needed for her dream career. And she made it. Elaine now leads her own lab, where she helps train the next generation of scientists and builds new knowledge about genetics.

### Footnotes

[1] Scientists are still working on untangling exactly how many wolf populations were involved in this process and where and when it occurred.

[2] Identifying these genes was a big part of the study, though not the focus of this Digging Data article. The process involved comparing the genomes of many sport-hunting dogs to the genomes of terriers (breeds selected to hunt vermin). The team looked for areas in the genome where 1) sport-hunting dogs tended to have one sequence and terriers tended to have a different sequence (suggesting that the two groups have evolved genetic differences from one another) and 2) the stretch of DNA sequence common in one of the groups of dogs was unusually long – that is, many dogs in one of the two groups (but not the other) had chromosomes with the exact same long genetic sequence at a particular location. This suggests that somewhere in that sequence is a genetic variant (allele) that was so advantageous that it became common quickly – so quickly that recombination didn't have time to mix up the sequence near the useful variant. This process is known as a selective sweep. So, in short, the team looked for parts of the dog genome where there was evidence of genetic differences between sport-hunting dogs and terriers and evidence that a selective sweep caused those differences to evolve.



## Adaptation

An adaptation is a feature that arose and was favored by natural selection for its current function. Adaptations help an organism survive and/or reproduce in its current environment.

Adaptations can take many forms: a behavior that allows better evasion of predators, a protein that functions better at body temperature, or an anatomical feature that allows the organism to access a valuable new resource — all of these might be adaptations. Many of the things that impress us most in nature are thought to be adaptations.

Mimicry of leaves by insects is an adaptation for evading predators. This example is a katydid from Costa Rica.



A side-facing image of a katydid, which looks like a leaf with six legs and antennae. Image © Greg Neise, GE Neise Digital Communication.

The creosote bush is a desert-dwelling plant that produces toxins that prevent other plants from growing nearby, thus reducing competition for nutrients and water.



A creosote bush. Image courtesy of US Geological Survey.

Echolocation in bats is an adaptation for catching insects.

So what's not an adaptation? The answer: a lot of things. One example is vestigial structures. A vestigial structure is a feature that was adaptive for the organism's ancestor, but that evolved to be non-functional because the organism's environment changed.

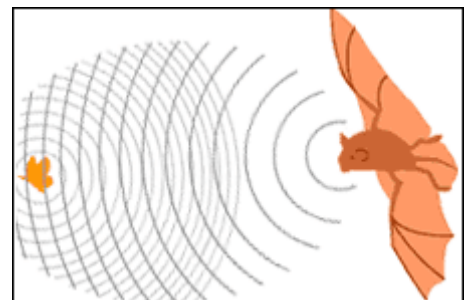

Echolocation illustration, UCMP

Fish species that live in completely dark caves have vestigial, non-functional eyes. When their sighted ancestors ended up living in caves, there was no longer any natural selection that maintained the function of the fishes' eyes. So fish with better sight no longer out-competed fish with worse sight. Today, these fish still have eyes — but they are not functional and are not an adaptation; they are just the by-products of the fishes' evolutionary history.



Milyeringa fish which has no eyes. Image courtesy of Wetland Care Australia.



### Misconceptions about natural selection

Because natural selection can produce amazing adaptations, it's tempting to think of it as an all-powerful force, urging organisms on, constantly pushing them in the direction of progress — but this is not what natural selection is like at all.

First, natural selection is not all-powerful; it does not produce perfection. It's all about getting genes into the next generation, and if your genes are “good enough” to do that, you don't have to be perfect. This should be clear just by looking around us: human populations carry genes that cause disease, plants may not have the genes to survive a drought, a predator may not be quite fast enough to catch her prey every time she is hungry. No population or organism is perfectly adapted.

Second, it's more accurate to think of natural selection as a process rather than as a guiding hand. Natural selection is the simple result of variation, differential reproduction, and heredity — it is mindless and mechanistic. It has no goals; it's not striving to produce “progress” or a balanced ecosystem.

---

**variation + differential reproduction + heredity = natural selection**

---



Evolution does not work this way.

This is why “need,” “try,” and “want” are not very accurate words when it comes to explaining evolution. The population or individual does not “want” or “try” to evolve, and natural selection cannot try to supply what an organism “needs.” Natural selection just selects among whatever variations exist in the population. The result is evolution.

At the opposite end of the scale, natural selection is sometimes interpreted as a completely random process. This is also a misconception. The genetic variation that occurs in a population because of mutation is random — but selection acts on that variation in a very non-random way: genetic variants that aid survival and reproduction are much more likely to become common than variants that don't. Natural selection is NOT random!



### Coevolution

The term coevolution is used to describe cases where two (or more) species reciprocally affect each other's evolution. So for example, an evolutionary change in the morphology of a plant, might affect the morphology of an herbivore that eats the plant, which in turn might affect the evolution of the plant, which might affect the evolution of the herbivore... and so on.

Coevolution is likely to happen when different species have close ecological interactions with one another. These ecological relationships include:

1. Predator/prey and parasite/host
2. Competitive species
3. Mutualistic species

Many cases of coevolution can be found between plants and insects. For example, plants and their pollinators are so reliant on one another and their relationships are sometimes so exclusive that biologists have good reason to think that “matches” between the two are the result of a coevolutionary process.

Another example involves Central American *Acacia* species, which have hollow thorns and pores at the bases of their leaves that secrete nectar. These hollow thorns are the exclusive nest-site of some species of ant that drink the nectar. But the ants are not just taking advantage of the plant — they also defend their acacia plant against herbivores.

This system is probably the product of coevolution: the plants would not have evolved hollow thorns or nectar pores unless their evolution had been affected by the ants, and the ants would not have evolved herbivore defense behaviors unless their evolution had been affected by the plants.



Acacia photo courtesy of Steve Prchal and the Sonoran Arthropod Studies Institute.



Red squirrel photo by P. Holroyd.



Crossbill photo by Noah Strycker CCBY-NC4.0

## A case study of coevolution: squirrels, birds, and the pinecones they love

In most of the Rocky Mountains, red squirrels are an important predator of lodgepole pine seeds. They harvest pinecones from the trees and store them through the winter. However, the pine trees are not defenseless: squirrels have a difficult time with wide pinecones that weigh a lot but have fewer seeds. Crossbill birds live in these places and also eat pine seeds, but the squirrels get to the seeds first, so those birds don't get as many seeds.

However, in a few isolated places, there are no red squirrels, and crossbills are the most important seed predator for lodgepoles. Again, the trees are not defenseless: crossbills have more difficulty getting seeds from cones with large, thick scales. But the birds have a mode of counterattack: crossbills with deeper, shorter, less curved bills are better able to extract seeds from tough cones.

Close ecological relationships (like the predator/prey relationship described above) set the stage for coevolution to occur. But did it actually happen in this case? To figure that out, we need evidence that suggests that the prey (the trees) have evolved in response to the predator (squirrels or birds) and that the predator has evolved in response to the prey. Researchers Craig Benkman, William Holimon, and Julie Smith set out to see if their observations would support the hypothesis of coevolution.

The scientists reasoned that if coevolution had occurred they would expect to observe the following:

- **Differences between pinecones from different regions**

If the trees have evolved in response to their seed predators, we should observe geographic differences in pinecones: where squirrels are the main seed predator, trees would have evolved stronger defenses against squirrel predation, and where birds are the main seed predator, trees would have evolved stronger defenses



Lodgepole pine photo by kendalloe CC BY-NC 4.0



Lodgepole pinecone (left) adapted to defend against squirrels – easier for crossbills to eat. Lodgepole pinecone (right) adapted to defend against crossbills – easier for squirrels to eat. Image of lodgepole cones courtesy of Ed Jensen, Oregon State University.



against bird predation. This turned out to be true. Where there are squirrels, the pinecones are heavier with fewer seeds, but have thinner scales, like the pinecone on the left. Where there are only crossbills, pinecones are lighter with more seeds, but have thick scales.

- **Geographic differences between predators that correspond to differences in prey**

If the crossbills have evolved in response to the pine trees, we should observe geographic differences in birds: where the pinecones have thick scales, birds would have evolved deeper, less curved bills, which are better for getting seeds out of tough cones, than they have where the pinecones have thin scales. This also turns out to be true.



The bill is less curved on this female red crossbill. Image of female red crossbill courtesy of Greg Lasley, Greg Lasley Nature Photography.



The bill is more deeply curved on this male red crossbill. Image of male red crossbill courtesy of Dennis Oehmke and the Illinois Raptor Center.

So we have evidence that the trees have experienced natural selection and adapted to the birds (and the squirrels) and that the birds have adapted to the trees. (However, note that we don't have evidence that the squirrels have adapted to the trees.) It's easy to see why this is called a coevolutionary arms race: it seems possible for the evolutionary "one-upping" to go on and on...even thicker-scaled pinecones are favored by natural selection, which causes deeper-billed birds to be favored, which causes even thicker-scaled pinecones to be favored, and so on...



### Microevolution

House sparrows have adapted to the climate of North America, mosquitoes have evolved in response to global warming, and insects have evolved resistance to our pesticides. These are all examples of microevolution — evolution on a small scale.

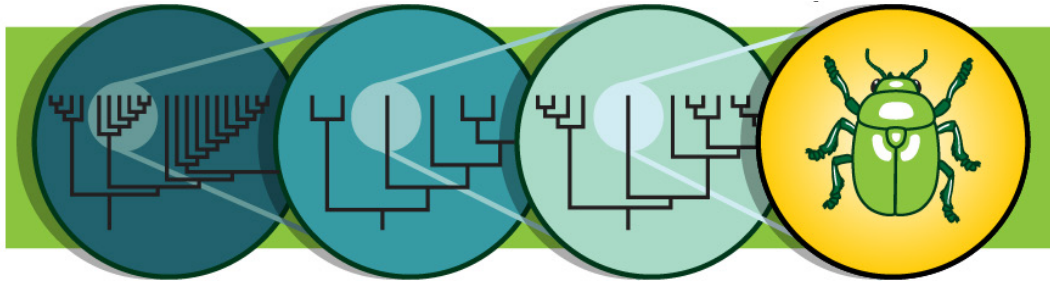

Here, you can explore the topic of microevolution through several case studies in which we've directly observed its action.

We can begin with an exact definition.



### Defining microevolution

Microevolution is evolution on a small scale — within a single population. That means narrowing our focus to one branch of the tree of life.

If you could zoom in on one branch of the tree of life scale — the insects, for example — you would see another phylogeny relating all the different insect lineages. If you continue to zoom in, selecting the branch representing beetles, you would see another phylogeny relating different beetle species. You could continue zooming in until you saw the relationships between beetle populations.

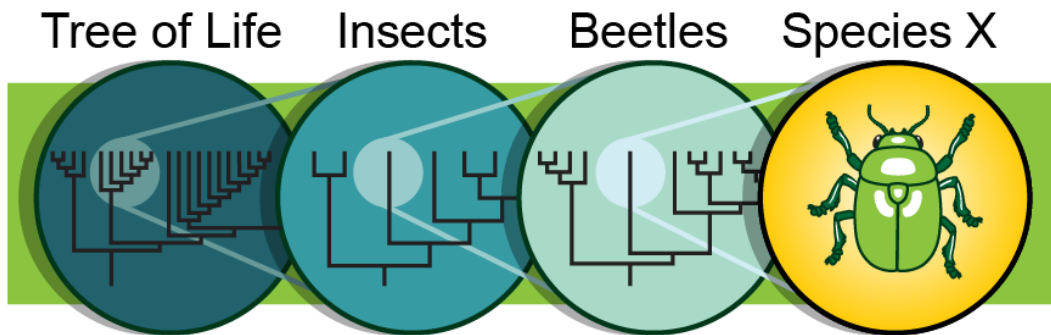

But how do you know when you've gotten to the population level?

### Defining populations

For animals, it's fairly easy to decide what a population is. It is a group of organisms that interbreed with each other — that is, they all share a gene pool. So for our species of beetle, that might be a group of individuals that all live on a particular mountaintop and are potential mates for one another.

Biologists who study evolution at this level define evolution as a change in gene frequency within a population.



Two beetles mating. The potential to interbreed in nature defines the boundaries of a population. Image courtesy of Northern Prairie Wildlife Research Center, USGS.



### Detecting microevolutionary change

We've defined microevolution as a change in gene frequency in a population and a population as a group of organisms that share a common gene pool — like all the individuals of one beetle species living on a particular mountaintop.

Imagine that you go to the mountaintop this year, sample these beetles, and determine that 80% of the genes in the population are for green coloration and 20% of them are for brown coloration. You go back the next year, repeat the procedure, and find a new ratio: 60% green genes to 40% brown genes.

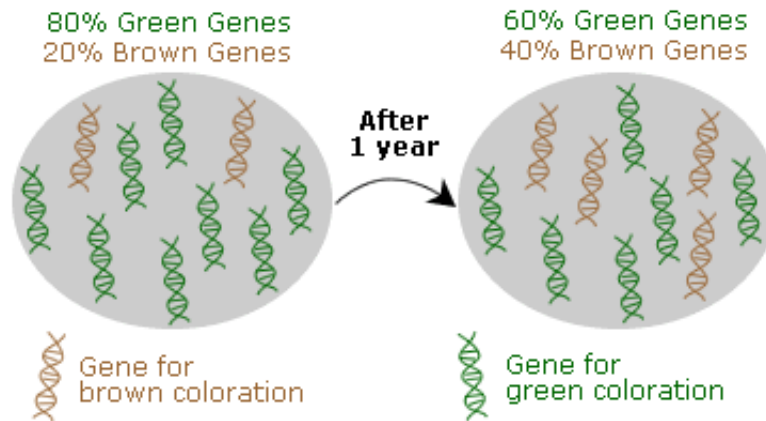

You have detected a microevolutionary pattern: a change in gene frequency. A change in gene frequency over time means that the population has evolved.

The big question is, how did it happen?



### Mechanisms of microevolution

There are a few basic ways in which microevolutionary change happens. Mutation, migration, genetic drift, and natural selection are all processes that can directly affect gene frequencies in a population.

Imagine that you observe an increase in the frequency of brown coloration genes and a decrease in the frequency of green coloration genes in a beetle population. Any combination of the mechanisms of microevolution might be responsible for the pattern, and part of the scientist's job is to figure out which of these mechanisms caused the change:

#### Mutation

Some “green genes” randomly mutated to “brown genes” (although since any particular mutation is rare, this process alone cannot account for a big change in allele frequency over one generation).

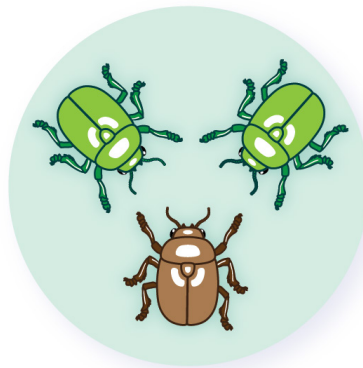

#### Migration (or gene flow)

Some beetles with brown genes immigrated from another population, or some beetles carrying green genes emigrated.

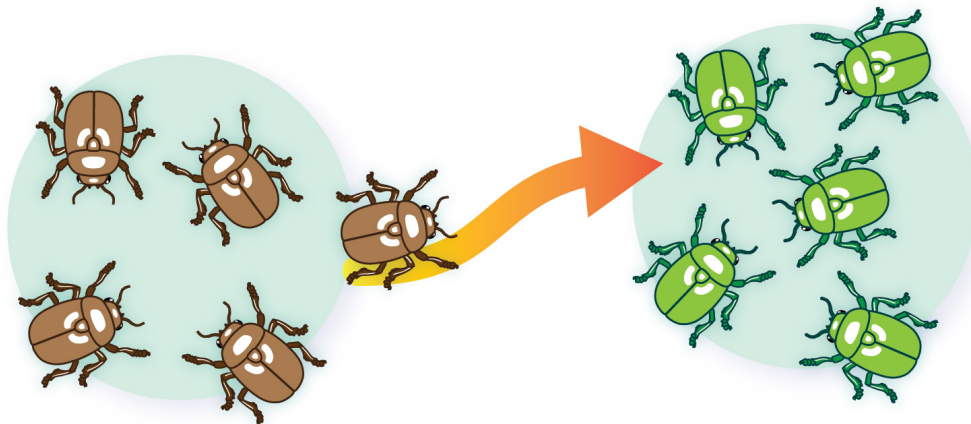



### Genetic drift

When the beetles reproduced, just by random luck more brown genes than green genes ended up in the offspring.



### Natural selection

Beetles with brown genes escaped predation and survived to reproduce more frequently than beetles with green genes, so that more brown genes got into the next generation.

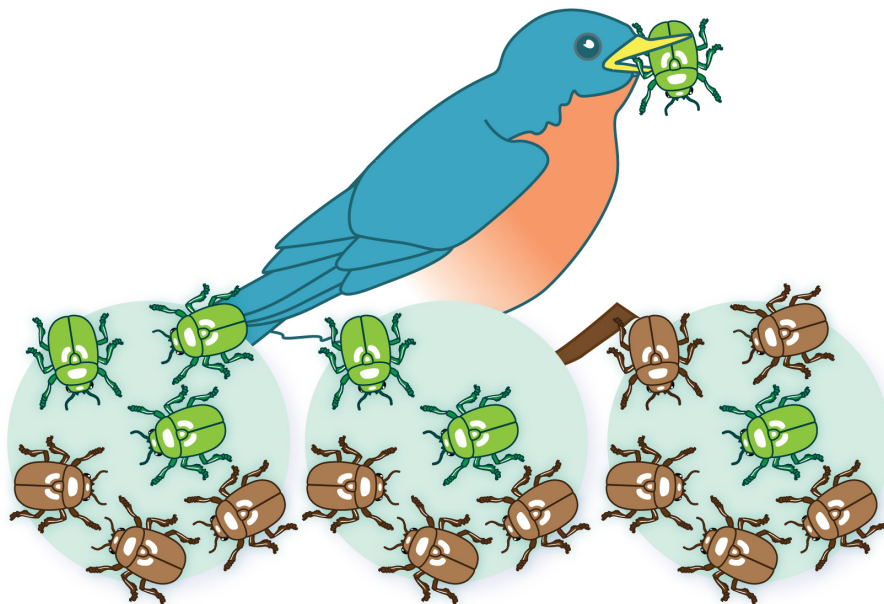



### Speciation

What are species anyway, and how do new ones evolve?

Here, you can explore different ways to define a species and learn about the various processes through which speciation can occur. This section also addresses the topics of cospeciation — when two lineages split in concert with one another — and modes of speciation that are specific to plants.

Let's start by defining a species.





## Defining a species

A species is often defined as a group of individuals that actually or potentially interbreed in nature. In this sense, a species is the biggest gene pool possible under natural conditions.

For example, these happy face spiders look different, but since they can interbreed, they are considered the same species: *Theridion grallator*.



Happy face spider photos courtesy of Rosemary Gillespie, UC Berkeley.

That definition of a species might seem cut and dried, but it is not — in nature, there are lots of places where it is difficult to apply this definition. For example, many bacteria reproduce mainly asexually. The bacterium shown at right is reproducing asexually, by binary fission. The definition of a species as a group of interbreeding individuals cannot be easily applied to organisms that reproduce only or mainly asexually.

Also, many plants, and some animals, form hybrids in nature. Hooded crows and carrion crows look different, and largely mate within their own groups — but in some areas, they hybridize. Should they be considered the same species or separate species?

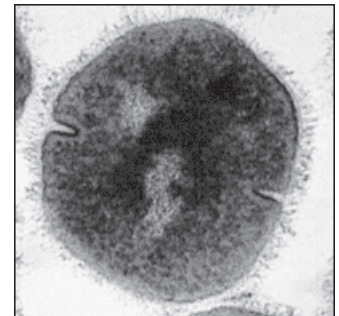

Streptococcus micrograph courtesy of Dr. Vincent A. Fischetti.

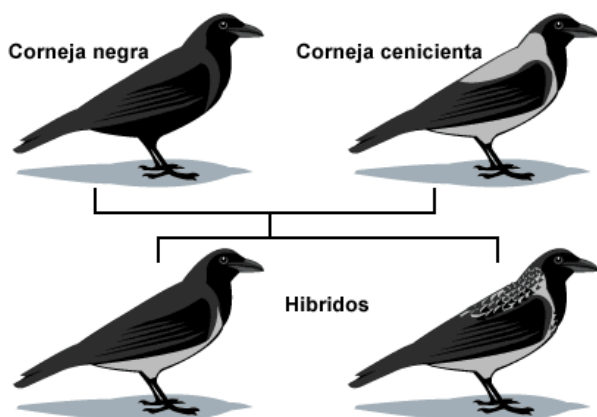

If two lineages of oak look quite different, but occasionally form hybrids with each other, should we count them as different species? There are lots of other places where the boundary of a species is blurred. It's not so surprising that these blurry places exist — after all, the idea of a species is something that we humans invented for our own convenience!



## Defining speciation

Speciation is a lineage-splitting event that produces two or more separate species. Imagine that you are looking at a tip of the tree of life that constitutes a species of fruit fly. Move down the phylogeny to where your fruit fly twig is connected to the rest of the tree. That branching point, and every other branching point on the tree, is a speciation event. At that point genetic changes resulted in two separate fruit fly lineages, where previously there had just been one lineage. But why and how did it happen?

The branching points on this partial *Drosophila* phylogeny represent long past speciation events. Here is one scenario that exemplifies how speciation can happen:

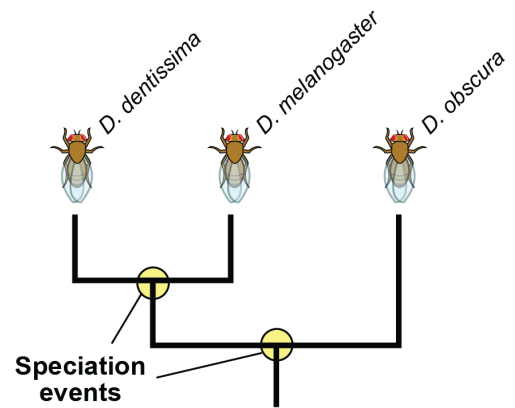

- **The scene:** a population of wild fruit flies minding its own business on several bunches of rotting bananas, cheerfully laying their eggs in the mushy fruit...



- **Disaster strikes:** A hurricane washes the bananas and the immature fruit flies they contain out to sea. The banana bunch eventually washes up on an island off the coast of the mainland. The fruit flies mature and emerge from their slimy nursery onto the lonely island. The two portions of the population, mainland and island, are now too far apart for gene flow to unite them. At this point, speciation has not occurred — any fruit flies that got back to the mainland could mate and produce healthy offspring with the mainland flies.

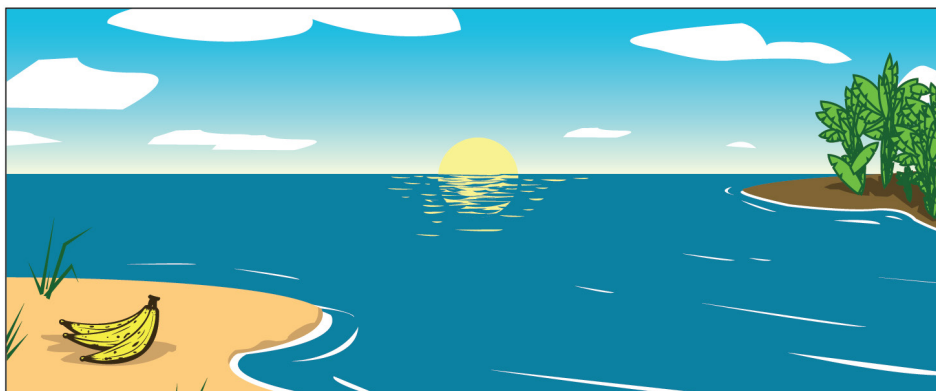



- **The populations diverge:** Ecological conditions are slightly different on the island, and the island population evolves under different selective pressures and experiences different random events than the mainland population does. Morphology, food preferences, and courtship displays change over the course of many generations of natural selection.

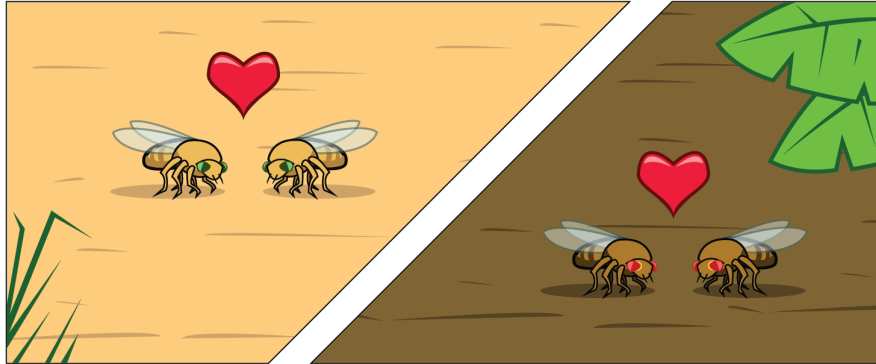

- **So we meet again:** When another storm reintroduces the island flies to the mainland, they will not readily mate with the mainland flies since they've evolved different courtship behaviors. The few that do mate with the mainland flies, produce inviable eggs because of other genetic differences between the two populations. The lineage has split now that genes cannot flow between the populations.

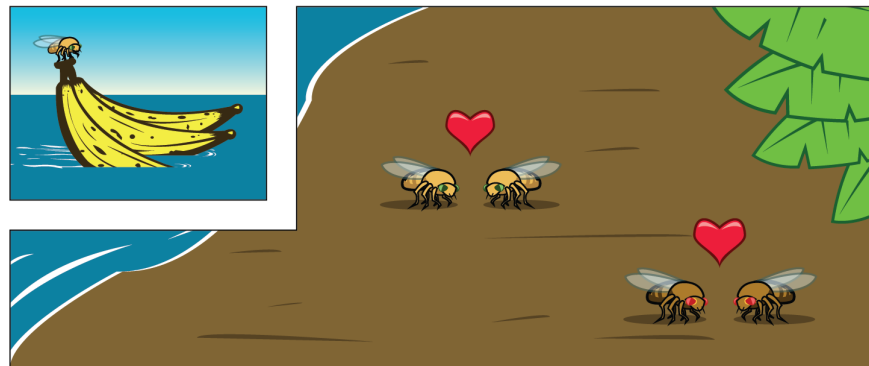

This is a simplified model of speciation by geographic isolation, but it gives an idea of some of the processes that might be at work in speciation. In most real-life cases, we can only put together part of the story from the available evidence. However, the evidence that this sort of process does happen is strong.



## Causes of speciation

### Geographic isolation

In the fruit fly example, some fruit fly larvae were washed up on an island, and speciation started because populations were prevented from interbreeding by geographic isolation. Scientists think that geographic isolation is a common way for the process of speciation to begin: rivers change course, mountains rise, continents drift, organisms migrate, and what was once a continuous population is divided into two or more smaller populations.

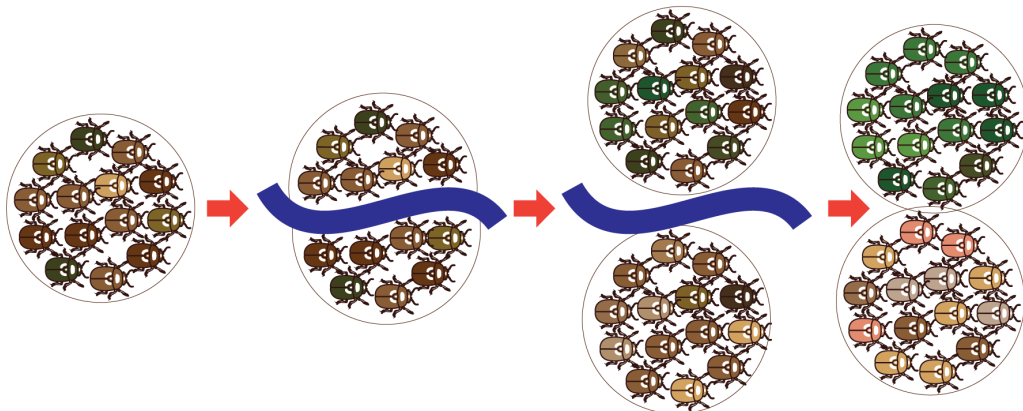

It doesn't even need to be a physical barrier like a river that separates two or more groups of organisms — it might just be unfavorable habitat between the two populations that keeps them from mating with one another.

### Reduction of gene flow

However, speciation might also happen in a population with no specific extrinsic barrier to gene flow. Imagine a situation in which a population extends over a broad geographic range, and mating throughout the population is not random. Individuals in the far west would have zero chance of mating with individuals in the far eastern end of the range. So we have reduced gene flow, but not total isolation. This may or may not be sufficient to cause speciation. Speciation would probably also require different selective pressures at opposite ends of the range, which would alter gene frequencies in groups at different ends of the range so much that they would not be able to mate if they were reunited.

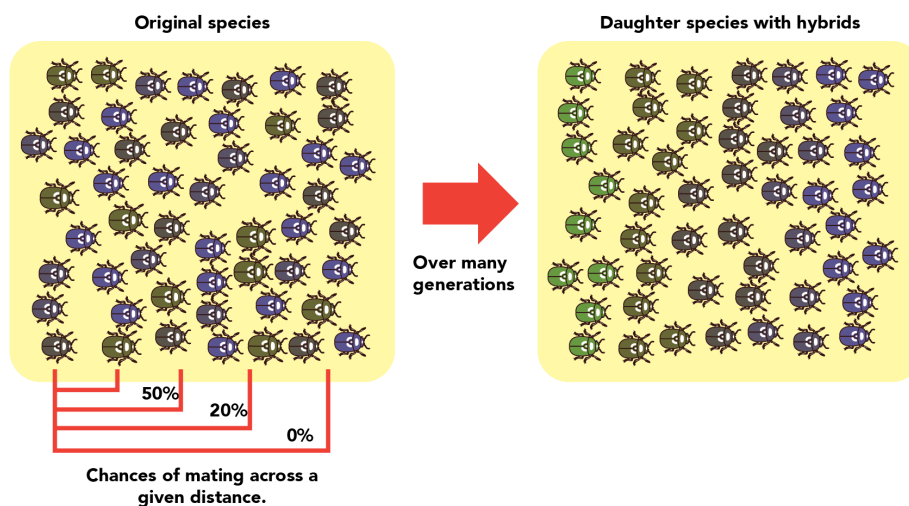

Even in the absence of a geographic barrier, reduced gene flow across a species' range can encourage speciation.



## Reproductive isolation

The environment may impose an external barrier to reproduction, such as a river or mountain range, between two incipient species but that external barrier alone will not make them separate, full-fledged species. Allopatry may start the process off, but the evolution of internal (i.e., genetically-based) barriers to gene flow is necessary for speciation to be complete. If internal barriers to gene flow do not evolve, individuals from the two parts of the population will freely interbreed if they come back into contact. Whatever genetic differences may have evolved will disappear as their genes mix back together. Speciation requires that the two incipient species be unable to produce viable offspring together or that they avoid mating with members of the other group.

Here are some of the barriers to gene flow that may contribute to speciation. They result from natural selection, sexual selection, or even genetic drift:

- **The evolution of different mating location, mating time, or mating rituals:**

Genetically-based changes to these aspects of mating could complete the process of reproductive isolation and speciation. For example, bowerbirds (shown below) construct elaborate bowers and decorate them with different colors in order to woo females. If two incipient species evolved differences in this mating ritual, it might permanently isolate them and complete the process of speciation.



Different species of bowerbird construct elaborate bowers and decorate them with different colors in order to woo females. The Satin bowerbird (left) builds a channel between upright sticks, and decorates with bright blue objects, while the MacGregor's Bowerbird (right) builds a tall tower of sticks and decorates with bits of charcoal. Evolutionary changes in mating rituals, such as bower construction, can contribute to speciation. Satin bowerbird photo courtesy of Graeme Guy. MacGregor's bowerbird photo courtesy of Stephen and Melinda Pruett-Jones.

- **Lack of “fit” between sexual organs:**

Hard to imagine for us, but a big issue for insects with variably-shaped genitalia!

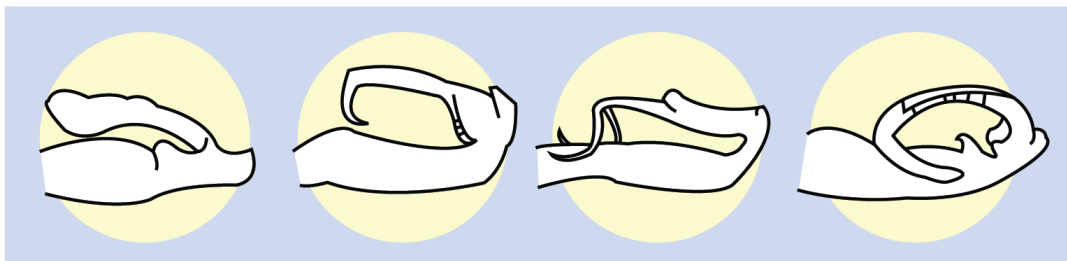

These damselfly penises illustrate just how complex insect genitalia may be. Image adapted from Eberhard, W.G. 1985. *Sexual Selection and Animal Genitalia*. Harvard University Press.

- **Offspring inviability or sterility:**

All that courting and mating is wasted if the offspring of matings between the two groups do not survive or cannot reproduce.

## Evolution 101: Speciation



In our fruit-flies-in-rotten-bananas-in-a-hurricane example, allopatry kicked off the speciation process, but different selection pressures on the island caused the island population to diverge genetically from the mainland population.

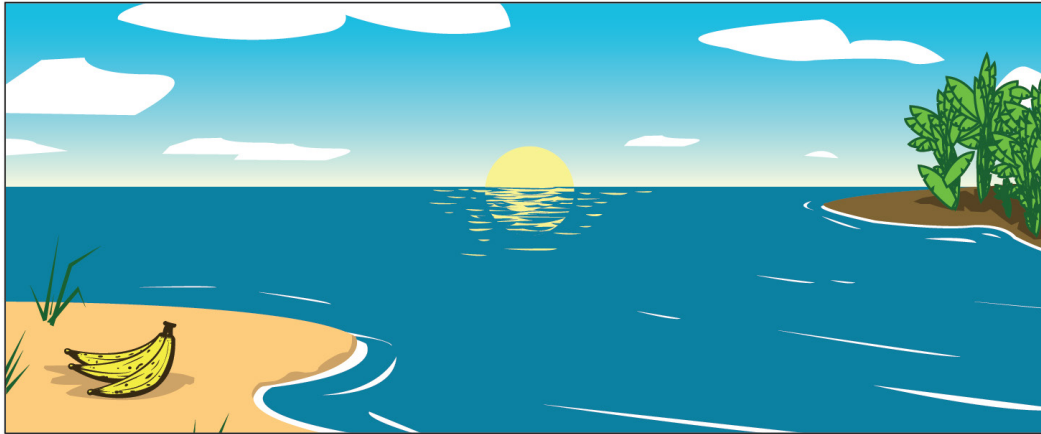

Geographic isolation can instigate a speciation event — but genetic changes are necessary to complete the process.

What might have caused that to happen? Perhaps, different fruits were abundant on the island. The island population was selected to specialize on a particular type of fruit and evolved a different food preference from the mainland flies.

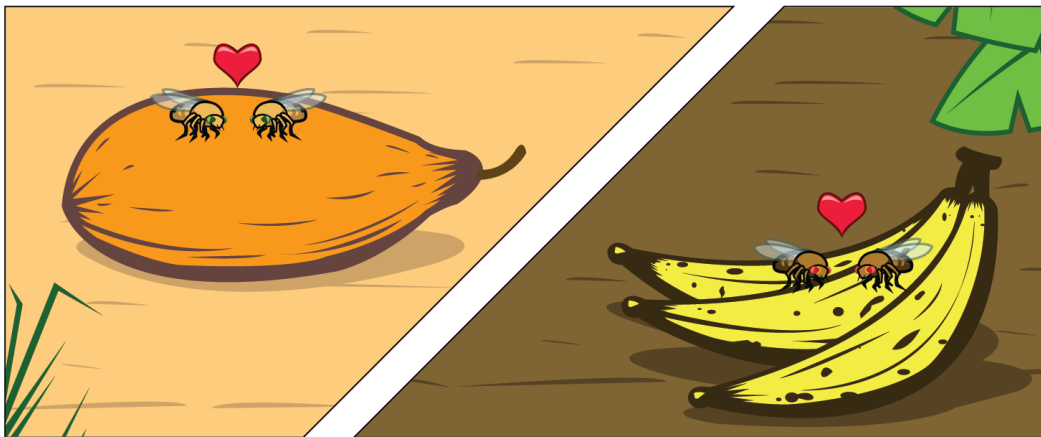

Differing selection pressures on the two islands can complete the differentiation of the new species.

Could this small difference be a barrier to gene flow with the mainland flies? Yes, if the flies find mates by hanging out on preferred foods, then if they return to the mainland, they will not end up mating with mainland flies because of this different food preference. Gene flow would be greatly reduced; and once gene flow between the two species is stopped or reduced, larger genetic differences between the species can accumulate.

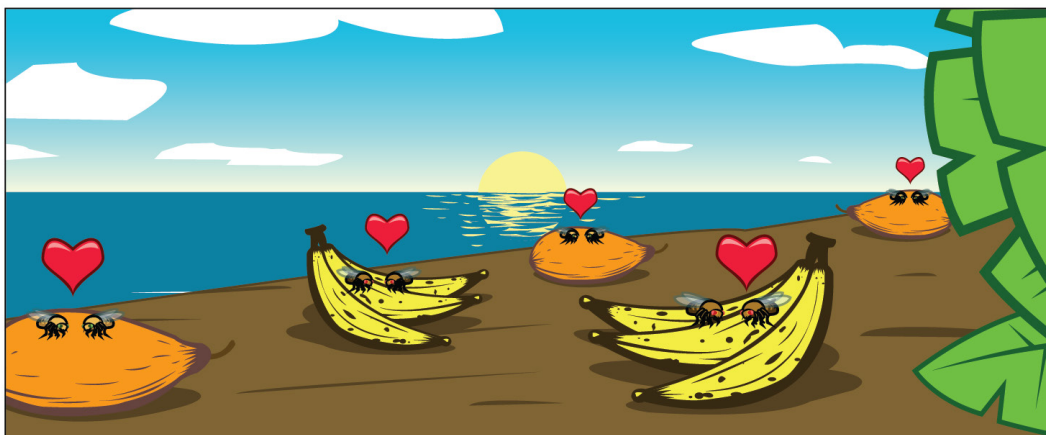



## Evidence for speciation

### Speciation in action?

In the summer of 1995, at least 15 iguanas survived Hurricane Marilyn on a raft of uprooted trees. They rode the high seas for a month before colonizing the Caribbean island, Anguilla. These few individuals were perhaps the first of their species, *Iguana iguana*, to reach the island. If there were other intrepid *Iguana iguana* colonizers of Anguilla, they died out before humans could record their presence.

Evolutionary biologists would love to know what happens next: will the colonizing iguanas die out, will they survive and change only slightly, or will they become reproductively isolated from other *Iguana iguana* and become a new species? We could be watching the first steps of an allopatric speciation event, but in such a short time we can't be sure.

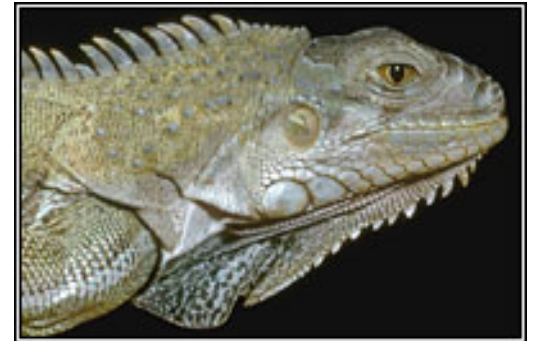

Iguana photo by George W. Robinson © California Academy of Sciences.

### A plausible model

We have several plausible models of how speciation occurs — but of course, it's hard for us to get an eye-witness account of a natural speciation event since most of these events happened in the distant past. We can figure out that speciation events happened and often *when* they happened, but it's more difficult to figure out how they happened. However, we can use our models of speciation to make predictions and then check these predictions against our observations of the natural world and the outcomes of experiments. As an example, we'll examine some evidence relevant to the allopatric speciation model.

Scientists have found a lot of evidence that is consistent with allopatric speciation being a common way that new species form:

- **Geographic patterns:** If allopatric speciation happens, we'd predict that populations of the same species in different geographic locations would be genetically different. There are abundant observations suggesting that this is often true. For example, many species exhibit regional "varieties" that are slightly different genetically and in appearance, as in the case of the Northern Spotted Owl and the Mexican Spotted Owl. Also, ring species are convincing examples of how genetic differences may arise through reduced gene flow and geographic distance.

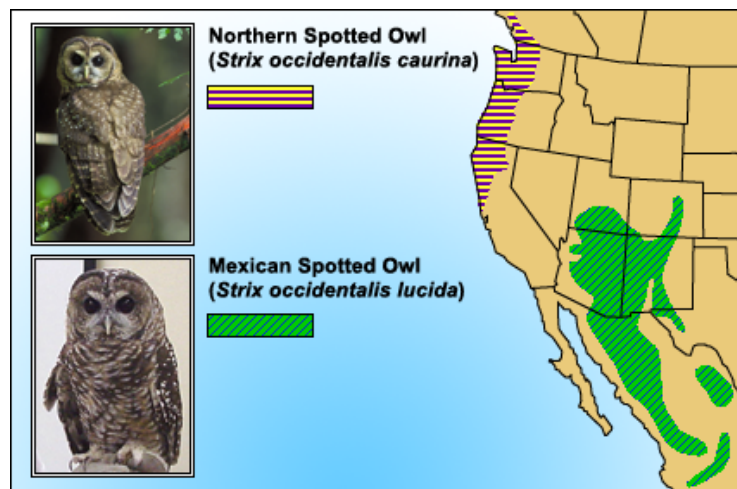

Spotted owl subspecies living in different geographic locations show some genetic and morphological differences. This observation is consistent with the idea that new species form through geographic isolation. Northern spotted owl photo by John and Karen Hollingsworth courtesy of U.S. Fish and Wildlife Service; Mexican spotted owl photo by Diane Knudsen courtesy of U.S. Fish and Wildlife Service.



- **Experimental results:** The first steps of speciation have been produced in several laboratory experiments involving “geographic” isolation. For example, Diane Dodd examined the effects of geographic isolation and selection on fruit flies. She took fruit flies from a single population and divided them into separate populations living in different cages to simulate geographic isolation. Half of the populations lived on maltose-based food, and the other populations lived on starch-based foods. After many generations, the flies were tested to see which flies they preferred to mate with. Dodd found that some reproductive isolation had occurred as a result of the geographic isolation and selection for different food sources in the two environments: “maltose flies” preferred other “maltose flies,” and “starch flies” preferred other “starch flies.” Although, we can’t be sure, these preference differences probably existed because selection for using different food sources also affected certain genes involved in reproductive behavior. This is the sort of result we’d expect, if allopatric speciation were a typical mode of speciation.

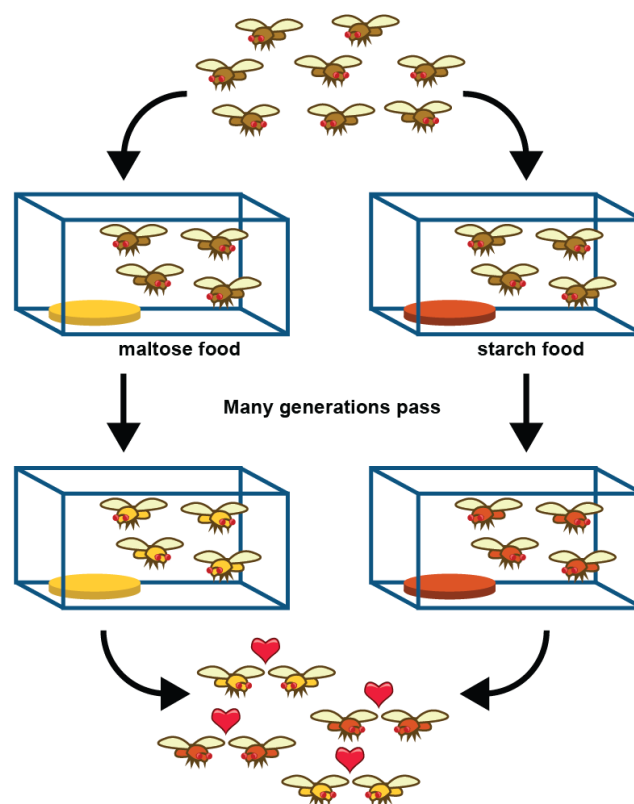

Diane Dodd's fruit fly experiment suggests that isolating populations in different environments (e.g., with different food sources) can lead to the beginning of reproductive isolation. These results are consistent with the idea that geographic isolation is an important step of some speciation events.



## Cospeciation

If the association between two species is very close, they may speciate in parallel. This is called cospeciation. It is especially likely to happen between parasites and their hosts.

To see how it works, imagine a species of louse living on a species of gopher. When the gophers get together to mate, the lice get an opportunity to switch gophers and perhaps mate with lice on another gopher. Gopher-switching allows genes to flow through the louse species.

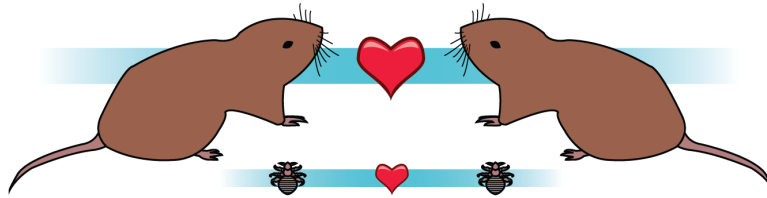

Consider what happens to the lice if the gopher lineage splits into lineages A and B:

1. Lice have few opportunities for gopher-switching, and lice on gopher lineage A don't mate with lice living on gopher lineage B.
2. This "geographic" isolation of the louse lineages may cause them to become reproductively isolated as well, and hence, separate species.

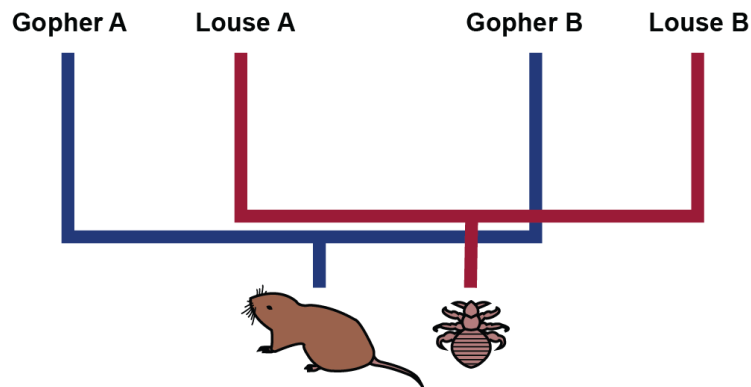



Evolutionary biologists can often tell when lineages have cospeciated because the parasite phylogeny will “mirror” the host phylogeny.

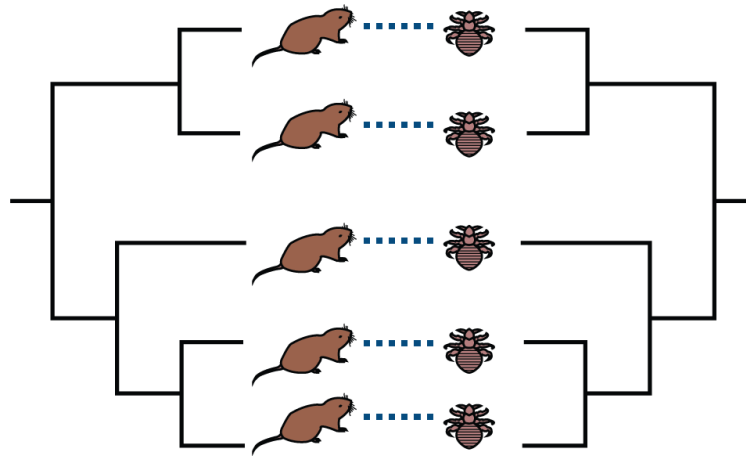

This example is somewhat idealized — rarely do scientists find hosts and parasites with exactly matching phylogenies. However, sometimes the phylogenies indicate that cospeciation did happen along with some host-switching.



## Macroevolution

Macroevolution is evolution on a grand scale — what we see when we look at the over-arching history of life: stability, change, lineages arising, and extinction.

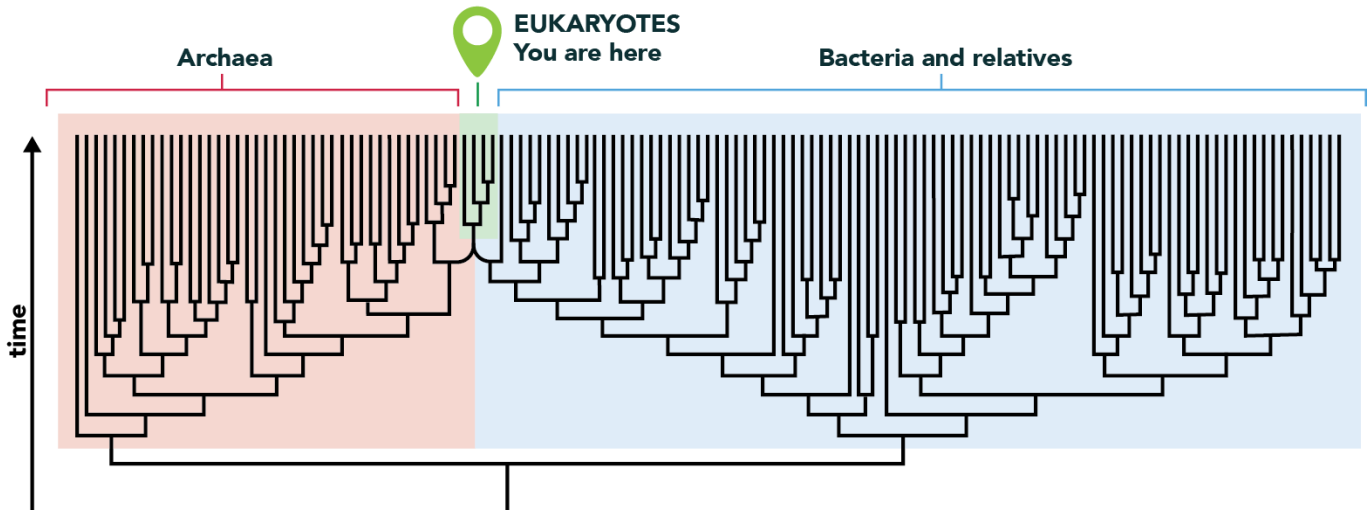

Tree of Life adapted from Hug et al. (2016)

Here, you can examine the patterns of macroevolution in evolutionary history and find out how scientists investigate deep history.



## What is macroevolution?

Macroevolution generally refers to evolution above the species level. So instead of focusing on an individual beetle species, a macroevolutionary lens might require that we zoom out on the tree of life, to assess the diversity of the entire beetle clade and its position on the tree.



Macroevolution refers to evolution of groups larger than an individual

Macroevolution encompasses the grandest trends and transformations in evolution, such as the origin of mammals and the radiation of flowering plants. Macroevolutionary patterns are generally what we see when we look at the large-scale history of life.

It is not necessarily easy to “see” macroevolutionary history; there are no firsthand accounts to be read. Instead, we reconstruct the history of life using all available evidence: geology, fossils, and living organisms.

Once we’ve figured out *what* evolutionary events have taken place, we try to figure out *how* they happened. Just as in microevolution, basic evolutionary mechanisms like mutation, migration, genetic drift, and natural selection are at work and can help explain many large-scale patterns in the history of life.

The basic evolutionary mechanisms — mutation, migration, genetic drift, and natural selection — can produce major evolutionary change if given enough time.

$$\begin{array}{l} \text{Mutation} \\ \text{Gene flow} \\ \text{Genetic drift} \\ \text{Natural selection} \end{array} + 3.8 \text{ billion years} = \text{Macroevolution}$$

A process like mutation might seem too small-scale to influence a pattern as amazing as the beetle radiation, or as large as the difference between dogs and pine trees, but it’s not. Life on Earth has been accumulating mutations and passing them through the filter of natural selection for 3.8 billion years — more than enough time for evolutionary processes to produce its grand history.



## Patterns in macroevolution

You can think of patterns as “what happened when.” All of the changes, diversifications, and extinctions that happened over the course of life’s history are the patterns of macroevolution.

However, beyond the details of individual past events — such as, when the beetle radiation began or what the first flowers looked like — biologists are interested in general patterns that recur across the tree of life:

1. **Stasis:** Many lineages on the tree of life exhibit stasis, which just means that they don’t change much for a long time, as shown in the figure to the right. In fact, some lineages have changed so little for such a long time that they are often called living fossils. Coelacanths comprise a fish lineage that branched off of the tree near the base of the vertebrate clade. Until 1938, scientists thought that coelacanths went extinct 80 million years ago. But in 1938, scientists discovered a living coelacanth from a population in the Indian Ocean that looked very similar to its fossil ancestors. Hence, the coelacanth lineage exhibits about 80 million years’ worth of morphological stasis.

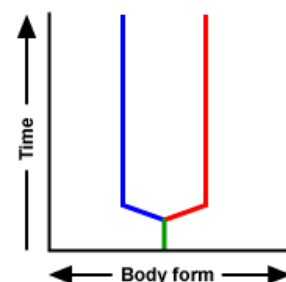

A coelacanth swimming near Sulawesi, Indonesia. Photo courtesy of Mark V. Erdmann.

2. **Character change:** Lineages can change quickly or slowly. Character change can happen in a single direction, such as evolving additional segments, or it can reverse itself by gaining and then losing segments. Changes can occur within a single lineage or across several lineages. In the figure to the right, lineage A changes rapidly but in no particular direction. Lineage B shows slower, directional change. Trilobites, animals in the same clade as modern insects and crustaceans, lived over 300 million years ago. As shown below, their fossil record clearly suggests that several lineages underwent similar increases in segment number over the course of millions of years.

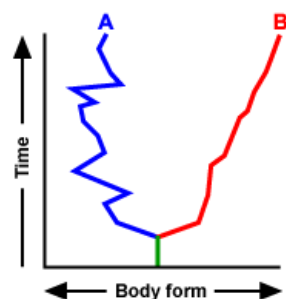

Changes in the number of ribs across eight trilobite lineages 

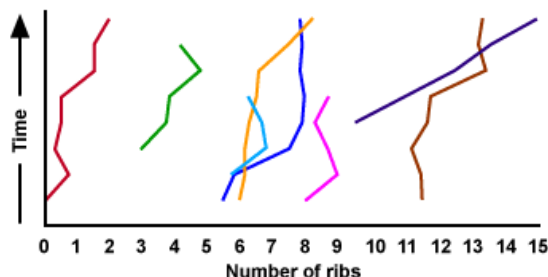



3. **Lineage-splitting** (or speciation): Patterns of lineage-splitting can be identified by constructing and examining a phylogeny. The phylogeny might reveal that a particular lineage has undergone unusually frequent lineage-splitting, generating a “bushy” tuft of branches on the tree (Clade A, below). It might reveal that a lineage has an unusually low rate of lineage-splitting, represented by a long branch with very few twigs coming off (Clade B, below). Or it might reveal that several lineages experienced a burst of lineage-splitting at the same time (Clade C, below).

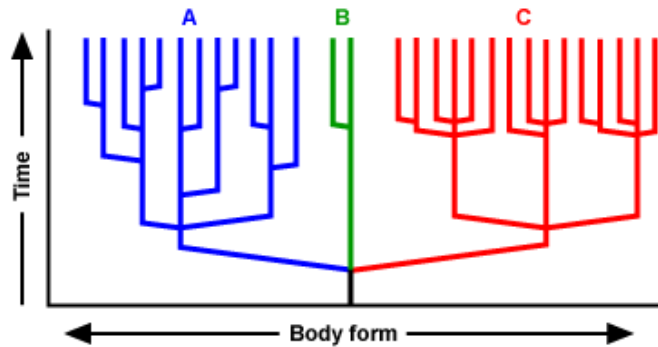

4. **Extinction:** Extinction is extremely important in the history of life. It can be a frequent or rare event within a lineage, or it can occur simultaneously across many lineages (mass extinction). Every lineage has some chance of becoming extinct, and overwhelmingly, species have ended up in the losing slots on this roulette wheel: over 99% of the species that have ever lived on Earth have gone extinct. In this diagram, a mass extinction cuts short the lifetimes of many species, and only three survive.

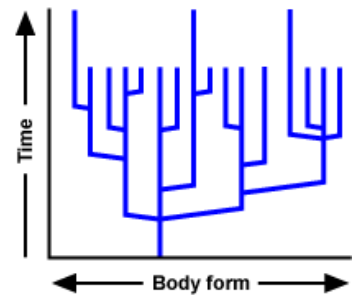

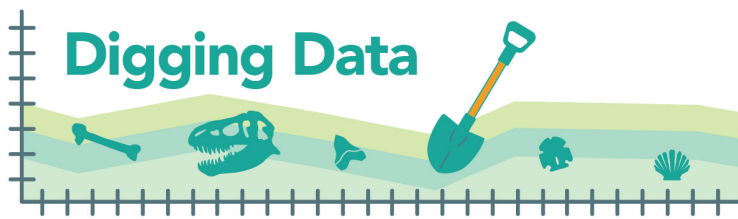

## Patterns in macroevolution

Extinction is a fact of the history of life. Just as new lineages have evolved over Earth's history, so, too, have lineages gone extinct. This balance of speciation and extinction has generated turnover in the set of species alive at each point in time. Biologists have long wondered if there are patterns in this churning of biodiversity. In particular, are there factors that predispose a species to extinction? Answering this question has taken on urgency as we face what is shaping up to be the Earth's 6th mass extinction, caused not by meteorite impacts or volcanic activity, but by humans. If we could figure out which species are most vulnerable to extinction, perhaps we could work out better ways to protect them.



Melissa Kemp, Assistant Professor at the University of Texas at Austin, excavating a cave site in the Caribbean. Photo provided by Melissa Kemp.

Biologists have already found that large body size is a risk factor for extinction. Several intuitive hypotheses could explain this. Larger organisms often reproduce more slowly, producing fewer offspring and taking longer to mature, so they can't bounce back as quickly if their numbers are reduced. Larger organisms also often have smaller population sizes to begin with and require a larger home range to sustain those populations, putting them at risk of extinction if part of that range is made uninhabitable. This pattern (increased risk of extinction with larger body sizes) has been observed in several different animal groups. For example, among living bird species, birds with larger bodies are more likely to be at higher risk of extinction. Biologists Melissa Kemp and Elizabeth Hadly wondered if it might also hold true for lizards in the Caribbean, a biodiversity hotspot, over the last few million years. **Are larger body sizes associated with greater risk of extinction in Caribbean lizards?**



Liz Hadly, Professor at Stanford University, in Nepal while doing fieldwork on Pikas. Photo by Uma Ramakrishnan.



## Hypotheses

Melissa and Liz investigated their question using statistical tests that rely on a null hypothesis. A null hypothesis proposes that there is *no* difference or *no* association between variables. If your statistical tests rejects the null hypothesis, then you know that the patterns in the data are not due to chance alone and are likely meaningful. Hence, the team's null hypotheses were:

1. **Extinct Caribbean lizard species have the same distribution of body sizes as living Caribbean lizard species.** Larger species are not particularly likely to have gone extinct over the last 2.6 million years.
2. **Among modern Caribbean lizards, threatened species have the same distribution of body sizes as those not at risk of extinction (i.e., species of “least concern”).** Among modern species, larger species are not particularly likely to be at elevated risk of extinction. Testing these null hypotheses required comparing data from modern lizard species to data from fossils. However, this introduced a potential bias to the study. What if larger or smaller species are more likely to show up in the fossil record? That could cause a pattern in the data – one that Melissa and Liz might mistake for extinction bias, when it was really preservation bias (which species are more likely to fossilize). To rule out this possibility, Melissa and Liz needed to check one more null hypothesis:
3. **Caribbean lizard species known from fossils have the same distribution of body sizes that those known from modern-day field studies.** Fossilization is not size-biased.

This table summarizes all three null hypotheses:

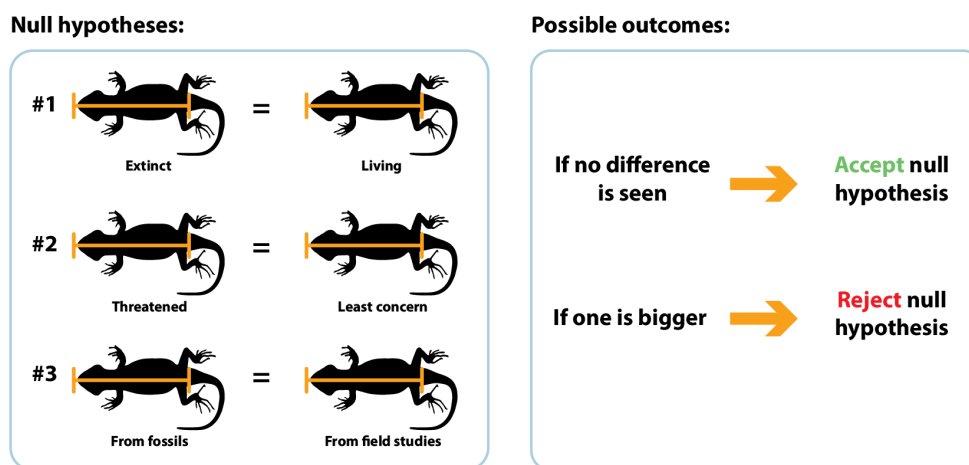

## Data

To test their hypotheses, Melissa and Liz needed a lot of data on body size in both modern and ancient Caribbean lizards, as well as information about which species went extinct and which are currently threatened with extinction. Luckily, a lot of these data had already been collected by other researchers. Melissa and Liz put together their data set from previously published studies, estimating the body size of extinct lizards from the sizes of fossilized bones and closely related modern species. Body size was indicated by the distance between the tip of a lizard's snout and its cloacal slit – aka, the snout-vent length (SVL). To make patterns in the data easier to see and work with, they use math to transform the data. Specifically, they took the log of the SVL for all their lizard species. This changes the magnitude of each data point, but keeps the relationships among data points the same (e.g., the largest raw number is still the largest after log-transformation). They divided modern species into “threatened” or “non-threatened” based on their conservation status according to the IUCN (International Union for Conservation of Nature) Red List.

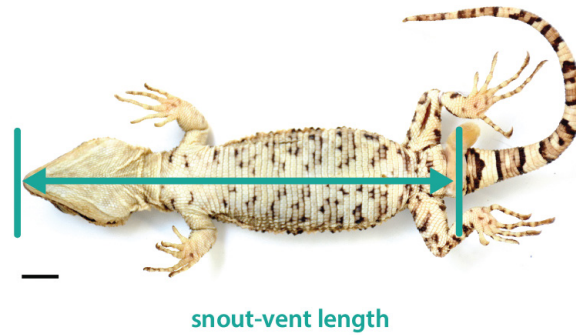

**Testing null hypothesis 3 – Do species known from fossils have the same range of sizes as species known from modern field studies?** Though this question was not the main point of the study, knowing its answer would be key in interpreting the data for null hypothesis 1.

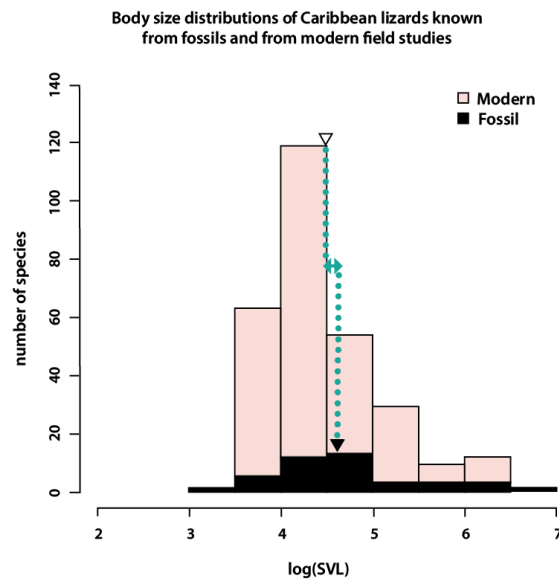

It's clear from this graph (and its much longer pink bars) that there are lots more species known from modern field studies than from studies of fossils. But does one group tend to have *larger* species than the other? Body size is shown on the x-axis. The triangles in the graph above represent the mean log body size for each group, and they appear to be similar (see blue annotation). Statistics can tell us if that small difference is likely a meaningful pattern or one that could easily be due to chance alone. Melissa and Liz performed a Kolmogorov-Smirnov test, which calculates the likelihood that two samples come from the same underlying distribution (i.e., are statistically “the same”). The  $p$ -value was 0.11, indicating that 11% of samples drawn from the same distribution would differ by this much or more just by chance alone. The usual cut-off for a significant difference is 5%, so they did *not* reject this null hypothesis, meaning that the small differences between the size of modern and fossil species in this sample could easily be caused by chance alone and not by a true difference between the overall sizes of the groups. In other words, fossilization does not appear to be size-biased in this group. That meant that whatever patterns Melissa and Liz found while investigating their other hypotheses are likely to represent real differences in body size and extinction risk.

## Testing null-hypotheses 1 and 2 – Do extinct and threatened species have the same distribution of body sizes as living and “least concern” species?

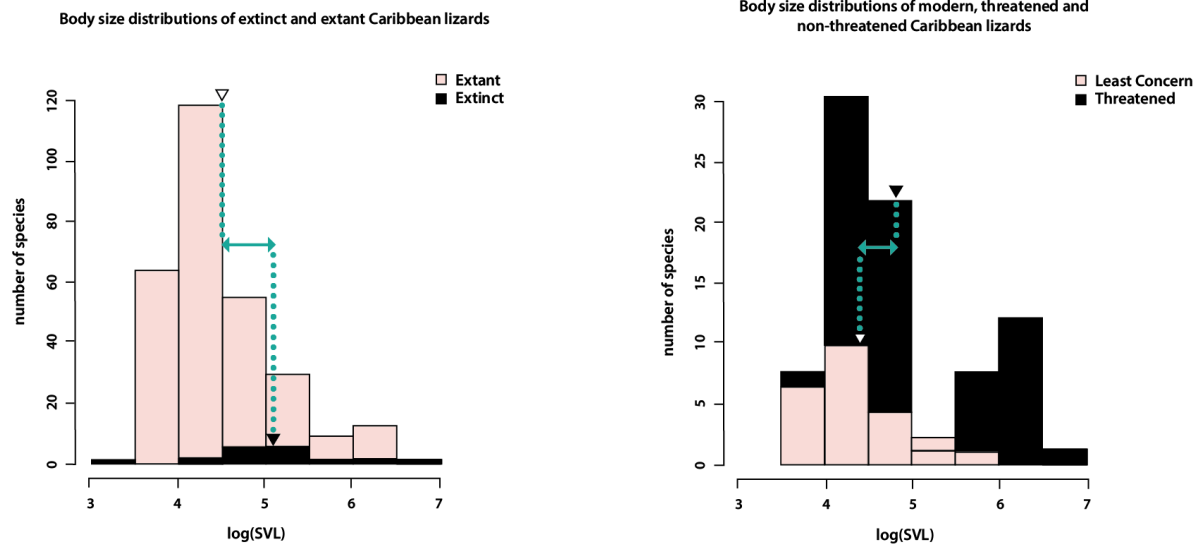

In these graphs, the triangles again represent the mean log body size of each group. At left, in the blue annotation, we can see that extinct species tend to have larger body sizes than extant (living) species. At right, we can see that threatened species tend to have larger body sizes than species of least concern. Are these differences significant? Melissa and Liz’s statistical tests showed that they are. Fewer than one in a thousand samples drawn from the same distribution would have had the observed or greater size differences between extinct and extant species ( $p < 0.001$ ) by chance alone. And fewer than three in a thousand samples would have had the observed or greater size differences between threatened and least concern species ( $p < 0.003$ ) by chance alone. This means that it is extremely *unlikely* that the observed size differences occurred by chance alone, and much *more* likely that there were true differences between the two sample sets. The researchers’ data led them to reject both of their other null hypotheses: extinct Caribbean lizard species are larger than living Caribbean lizard species, and threatened Caribbean lizard species *are* larger than “least concern” Caribbean lizard species.

This is yet another line of evidence suggesting that body size matters when it comes to extinction – larger Caribbean lizard species are more likely to have gone extinct in the past and are more likely to be threatened or endangered today. What we still don’t fully understand, however, is *why*? Do large, slow-reproducing lizard species evolve slowly and so don’t adapt to environmental changes as efficiently as smaller species? Is it that they require larger home ranges and are more vulnerable to extinction via habitat loss? Answering these questions will shed even more light on what we can do to optimize our conservation efforts.

### Stepping into science

Melissa loves to paint and draw. She thought she would grow up to be an artist. Today she finds that the approaches that informed her art – her appreciation for nature, perseverance, and eye for detail – make her a better scientist too! Liz didn’t set out to be a scientist either. She had never had a science or math teacher who was a woman, so couldn’t picture having that job. Now she’s the role model she didn’t have as a girl!



## The big issues

All available evidence supports the central conclusions of evolutionary theory, that life on Earth has evolved and that species share common ancestors. Biologists are not arguing about these conclusions. But they are trying to figure out how evolution happens, and that's not an easy job. It involves collecting data, proposing hypotheses, creating models, and evaluating other scientists' work. These are all activities that we can, and should, hold up to our checklist and ask the question: are they doing science?

All sciences ask questions about the natural world, propose explanations in terms of natural processes, and evaluate these explanations using evidence from the natural world. Evolutionary biology is no exception. Darwin's basic conception of evolutionary change and diversification (illustrated with a page from his notebook at right) explains many observations in terms of natural processes and is supported by evidence from the natural world.

Some of the questions that evolutionary biologists are trying to answer include:

1. Does evolution tend to proceed slowly and steadily or in quick jumps?
2. Why are some clades very diverse and some unusually sparse?
3. How does evolution produce new and complex features?
4. Are there trends in evolution, and if so, what processes generate them?

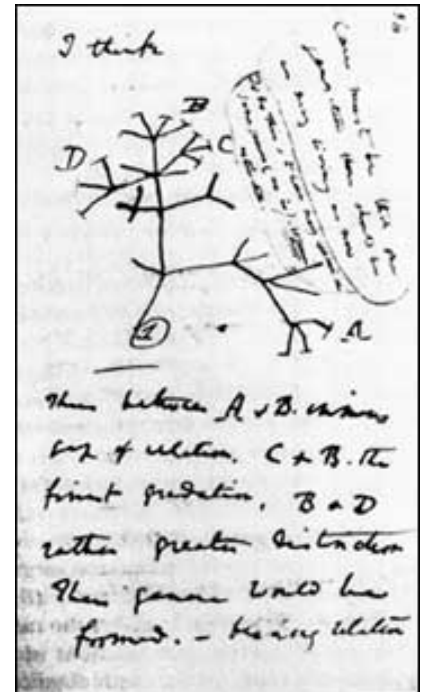

A page from Darwin's notebook. Used by permission of the Syndics of Cambridge University Library and may not be reproduced without their written permission.



## The pace of evolution

Does evolution occur in rapid bursts or gradually? This question is difficult to answer because we can't replay the past with a stopwatch in hand. However, we can try to figure out what patterns we'd expect to observe in the fossil record if evolution did happen in bursts, or if evolution happened gradually. Then we can check these predictions against what we observe.

### What should we observe in the fossil record if evolution is slow and steady?

If evolution is slow and steady, we'd expect to see the entire transition, from ancestor to descendant, displayed as transitional forms over a long period of time in the fossil record.

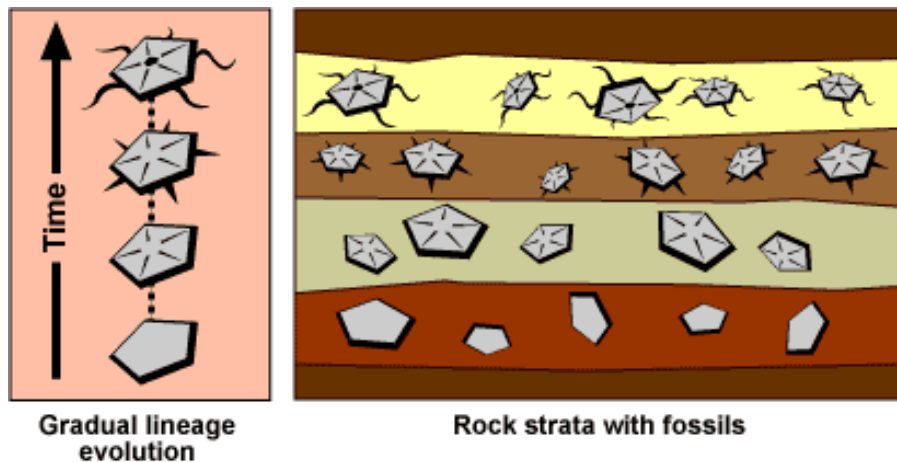

In the above example, the preservation of many transitional forms, through layers representing a length of time, gives a complete record of slow and steady evolution.

In fact, we see many examples of transitional forms in the fossil record. For example, to the right we show just a few steps in the evolution of whales from land-dwelling mammals, highlighting the transition of the walking forelimb to the flipper.

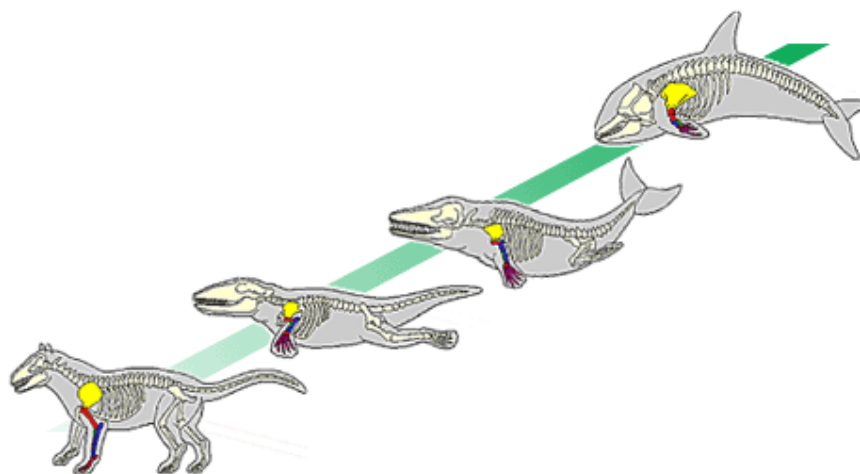

Transitional forms in whale evolution.

**What would we observe in the fossil record if evolution happens in “quick” jumps (perhaps fewer than 100,000 years for significant change)?** If evolution happens in “quick” jumps, we'd expect to see big changes happen quickly in the fossil record, with little transition between ancestor and descendant.

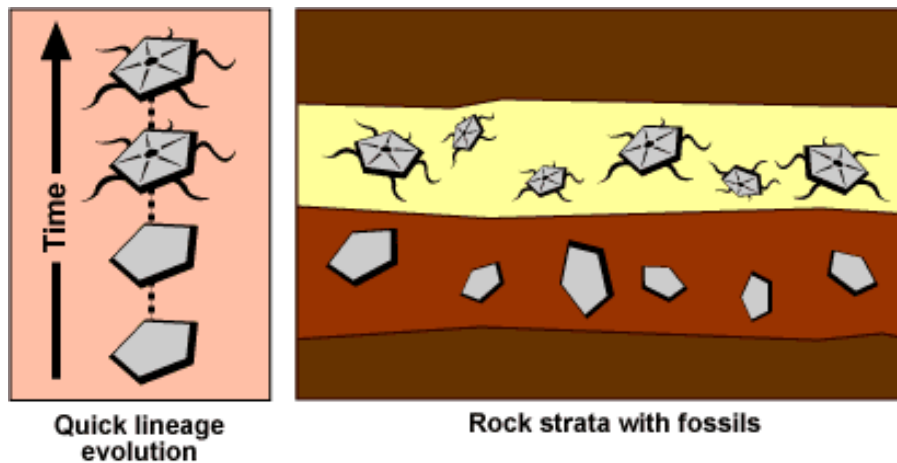

In the above example, we see the descendant preserved in a layer directly after the ancestor, showing a big change in a short time, with no transitional forms.

When evolution is rapid, transitional forms may not be preserved, even if fossils are laid down at regular intervals. We see many examples of this “quick” jumps pattern in the fossil record.

### Does a jump in the fossil record necessarily mean that evolution has happened in a “quick” jump?

We expect to see a jump in the fossil record if evolution has occurred as a “quick” jump, but a jump in the fossil record can also be explained by irregular fossil preservation.

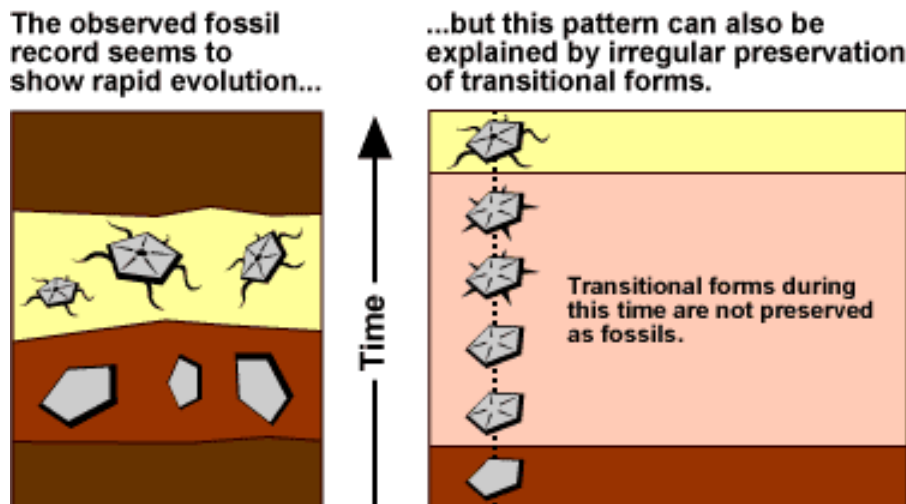

This possibility can make it difficult to conclude that evolution has happened rapidly.

We observe examples of both slow, steady change and rapid, periodic change in the fossil record. Both happen. But scientists are trying to determine which pace is more typical of evolution and how each sort of evolutionary change happens.



## Diversity in clades

Imagine that you've traveled back in time to around 350 million years ago, give or take 50 million years. Your goal is to check out the cool insects living at this point in time. You see a lot of little insects that look like modern silverfish — no big deal. Imagine that you've traveled back in time to around 350 million years ago, give or take 50 million years. Your goal is to check out the cool insects living at this point in time. You see a lot of little insects that look like modern silverfish — no big deal.



Silverfish photo courtesy of T.W. Davies © California Academy of Sciences.

But something interesting and significant is happening that you can't see — a lineage has split into two. One of these newly isolated lineages will eventually give rise to about 400 extant species that look a lot like the ancient insects you see. But the other lineage will give rise to millions of extant insect species, the bulk of animal life on Earth today. Why is there such a big difference in diversity between these two lineages? After all, they were indistinguishable 350 million years ago...

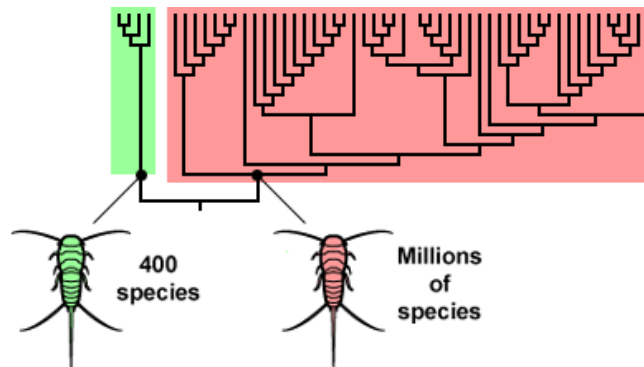

### Why would one lineage lead to millions of species and the other to only 400?

1. **Opportunity knocks:** One possibility is that the now-diverse lineage happened to be in the right place at the right time. The environment presented opportunities, and the lineage was able to take advantage of them. What sorts of factors in the environment might encourage diversification?
  - The environment may have offered opportunities for specialization.
  - A fragmented environment might make reproductive isolation likely.
  - The environment may have provided a release from competition with other insects.

All of these factors might be at work in some situations. Consider a plant-eating insect that colonizes a tropical island. On its mainland home, the insect's population size and range of resources is constrained by other species competing for the same resources. But the lack of similar species on the island means open niches and reduced competition from other species. Further, the island offers new kinds of food in the form of plants that the insect has never seen before. Selection might allow some insects to specialize on these new plants. Hanging around each kind of plant might mean that the insects get to mate with insects on a different plant less frequently, encouraging



reproductive isolation. All of these factors can drive diversification — *but only* if the population has the genetic variation to take advantage of the opportunities presented by the environment.



Being in the right place at the right time is a reason that one clade might be more diverse than another.

2. **Adaptive Radiation:** If all of this diversification happens in a short amount of time, it is often referred to as an adaptive radiation. Although biologists have different standards for defining an adaptive radiation, it generally means an event in which a lineage rapidly diversifies, with the newly formed lineages evolving different adaptations. The rapid diversification of mammals shown below may constitute an adaptive radiation.

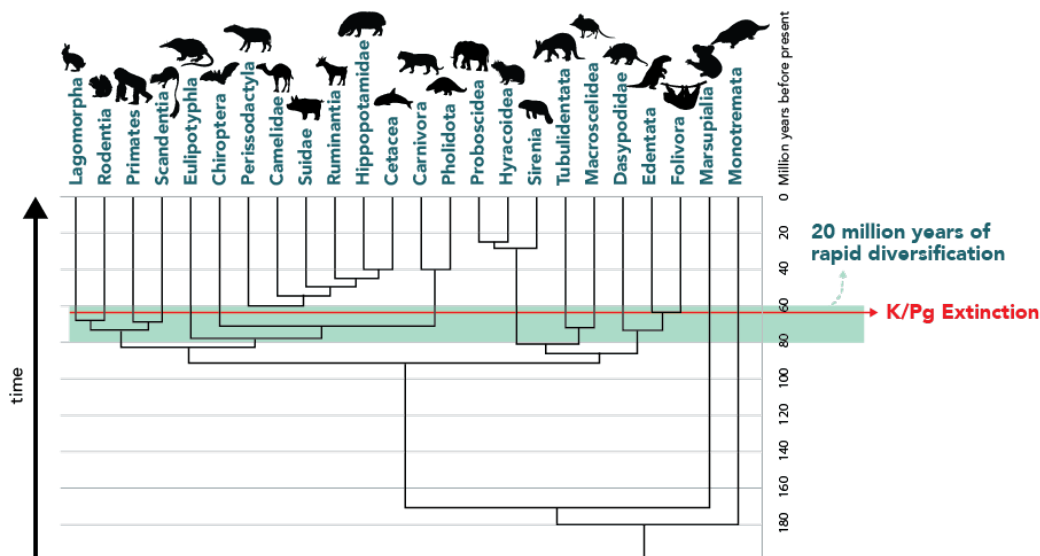

Tree adapted from Upham, N.S., Esselstyn, J.A., Jetz, W., 2019. Inferring the mammal tree: Species-level sets of phylogenies for questions in ecology, evolution, and conservation. PLoS Biol 17, e3000494. <https://doi.org/10.1371/journal.pbio.3000494> Tree adapted from Upham, N.S., Esselstyn, J.A., Jetz, W., 2019. Inferring the mammal tree: Species-level sets of phylogenies for questions in ecology, evolution, and conservation. PLoS Biol 17, e3000494. <https://doi.org/10.1371/journal.pbio.3000494>

3. **Historical changes in diversity:** Many events have left their marks on the diversity of life on Earth, pruning or growing the tree of life, but a few stand out as unusually important:
  - a. **Explosion:** About 530 million years ago, a huge variety of marine animals suddenly burst onto the evolutionary



scene. (Of course, “suddenly,” in geological terms, means in perhaps 10 million years). These animals had a variety of new body forms that evolution has been using to produce “spin-offs” ever since, such as these representatives from the Burgess Shale.

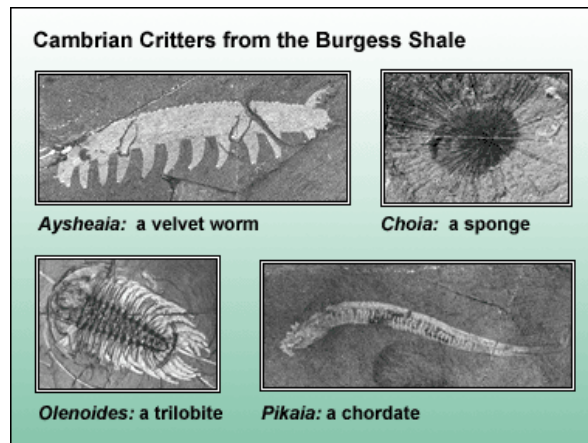

Images courtesy of Chip Clark, Museum of Natural History, Smithsonian Institution.

b. **Extinction:** About 225 million years ago, over 90% of the species alive at the time went extinct in fewer than 10 million years. Some groups that were dominant before the extinction never recovered. The cause of this extinction is the subject of much debate, but of equal significance is that it set the stage for a massive diversification of taxa that filled the empty niches.

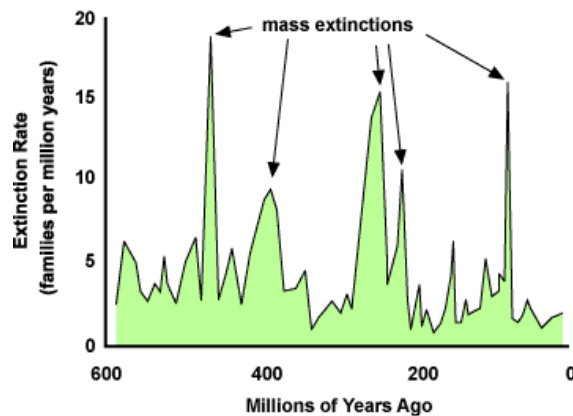



### Looking at complexity

Life is full of grand complications, such as aerodynamic wings, multi-part organs like eyes, and intricate chemical pathways. When faced with such complexity, both opponents and proponents of evolution, Darwin included, have asked the question: how could it evolve?



Complex adaptations: bird wings, insect wings, vertebrate eyes, and insect eyes. Gull photo courtesy of Dr. Lloyd Glenn Ingles © California Academy of Sciences; Butterfly photo © 2002 John White; Insect microscopy courtesy of Electron Microscope Lab UC Berkeley; Tree frog photo © 2003 Twan Leenders.

Science does not sweep such difficult questions under the rug, but takes them up as interesting areas for research. The difficulty is as follows.

Since many of these complex traits seem to be adaptive, they are likely to have evolved in small steps through natural selection. That is, intermediate forms of the adaptation must have evolved before evolution arrived at a fully-fledged wing, chemical pathway, or eye. But what good is half a wing or only a few of the elements of an eyeball? The intermediate forms of these adaptations may not seem adaptive — so how could they be produced by natural selection?

There are several ways such complex novelties may evolve:

- **Advantageous intermediates:** It's possible that those intermediate stages actually were advantageous, even if not in an obvious way. What good is “half an eye?” A simple eye with just a few of the components of a complex eye could still sense light and dark, like eyespots on simple flatworms do. This ability might have been advantageous for an organism with no vision at all and could have evolved through natural selection.

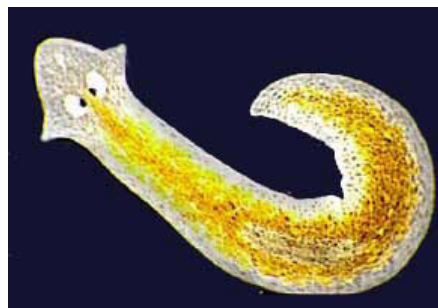

A Planaria flatworm with its light-sensitive eyespots. Photo courtesy of BioMEDIA ASSOCIATES.

- **Co-opting:** The intermediate stages of a complex feature might have served a different purpose than the fully-fledged adaptation serves. What good is “half a wing?” Even if it's not good for flying, it might be good for something else. The evolution of the very first feathers might have had nothing to do with flight and everything to do with insulation or display. Natural selection is an excellent thief, taking features that evolved in one context and using them for new functions.



## First Feathers

The fossil record indicates that birds are in fact a living clade of dinosaurs, and that dinosaurs evolved feathers before they could fly.

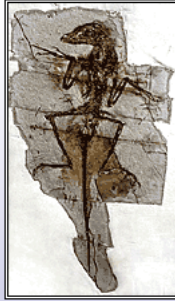

This is a small dinosaur from the dromaeosaur family.



Feather imprints were preserved along this dinosaur's bones. Here we can see feathers on the forearm.

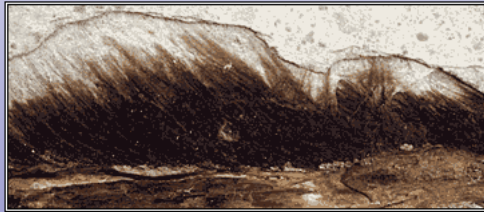

Here's a close-up of the fossil's head feathers.

This dinosaur could not fly, and it's possible that the initial evolution of feathers had nothing to do with flight.

Photos courtesy of Mick Ellison, AMNH.



## Trends in Evolution

An evolutionary trend can be either directional change within a single lineage or parallel change across lineages, in other words, several lineages undergoing the same sort of change. However, not just any change counts as a trend. After all, if the weather gets warmer one day, you wouldn't call it a warming trend; warming would have to go on for some length of time before you'd call it a trend. Biologists think about evolutionary trends in the same way — there has to be something about the change that suggests that it's not just a random fluctuation before it counts as a “trend.”

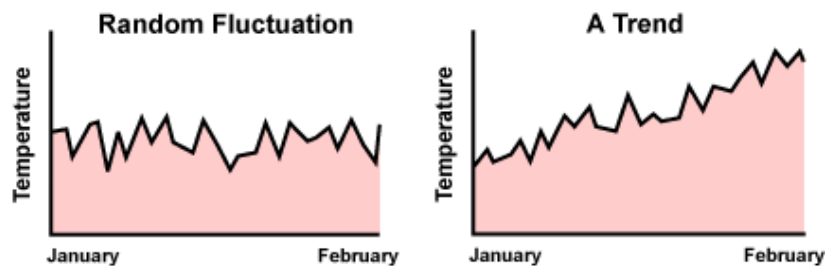

For example, titanotheres (a cool, extinct clade related to modern horses and rhinos) exhibit an evolutionary trend. Titanotheres had bony protuberances extending from their noses. The sequence of fossil skulls from these animals shows that evolutionary changes in the size of these “horns” were not random; instead, changes were biased in the direction of increasing horn size. And in fact, several different titanotheres lineages experienced the same sort of change in horn size.

The titanotheres reconstructions shown here range from about 55 mya (A) to 35 mya (D). The cause of this trend is not obvious. It may be a by-product of selection for increasing body size, and/or it may be a result of selection on horn size directly: big-horned individuals may have had an advantage in “butting” contests for females, as in sheep and goats.

Other evolutionary trends are not consistent across lineages. For example, biologists have long investigated whether there is a trend towards the evolution of larger body sizes. Since life started out so small, average body size has, of course, gone up over the course of life's history. There was no direction to go but bigger! And of course, many lineages have remained microscopic throughout 3.5 billion years of evolutionary history. Some groups of macroscopic organisms (like non-avian dinosaurs and marine species) *do* seem to have evolved larger and larger body sizes over time. But there are also many examples of lineages that show no particular trend at all (e.g., horses) or seem to evolve smaller body sizes than their ancestors – for example, in cases of island-dwelling and parasitic lineages.

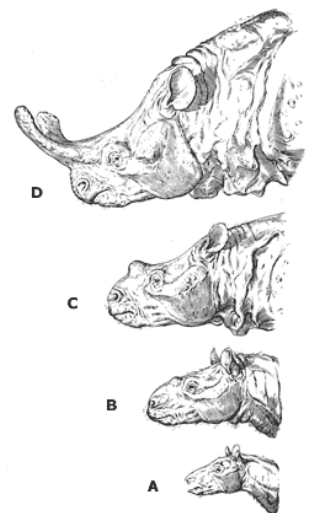
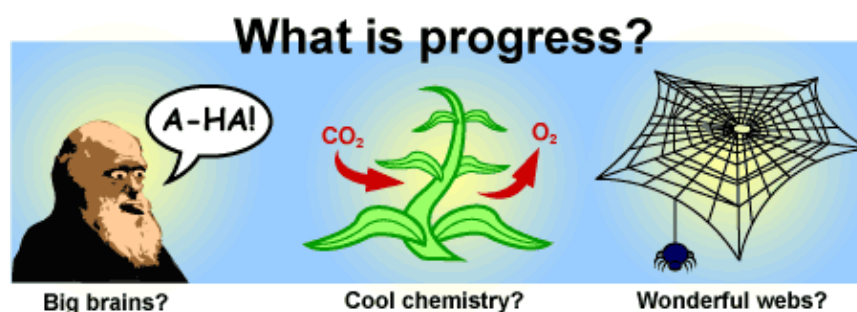

Illustration from Osborn, H.F. 1929 The titanotheres of ancient Wyoming, Dakota and Nebraska. U.S. Geol. Surv. Monogr. 55.

### Is evolution progressive?

This is not an easy question to answer. From a plant's perspective, the best measure of progress might be photosynthetic ability; from a spider's it might be the efficiency of a venom delivery system.





The problem is that we humans are hung up on ourselves. We often define progress in a way that hinges on our view of ourselves, a way that relies on intellect, culture, or emotion. But that definition is anthropocentric.

It is tempting to see evolution as a grand progressive ladder with *Homo sapiens* emerging at the top. But evolution produces a tree, not a ladder — and we are just one of many leaves on the tree.



**wrong**



**right**