

一株鸽源新城疫病毒HN基因分析

Analysis of HN gene from a novel pigeon NDV

汇报人：王 琪

小组成员：李连峰，张晓战，董书伟

2013.12.1

项目背景

- 新城疫（newcastle disease,ND）是由新城疫病毒（NDV）引起禽的严重的呼吸道疫病，OIE将其列为A类疫病，危害严重。



研究背景

新城疫 (Newcastle disease, ND)

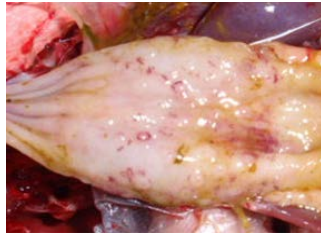

- 急性
- 高度接触性
- 宿主谱广



Chickens are highly susceptible



pheasant
野鸡



moscovey duck



turkey



mallard



goose

研究背景

新城疫病毒 (Newcastle disease virus, NDV)

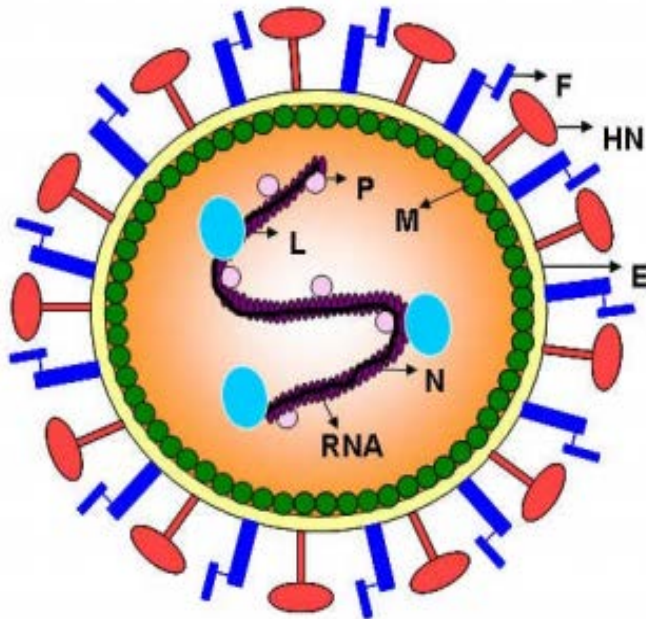
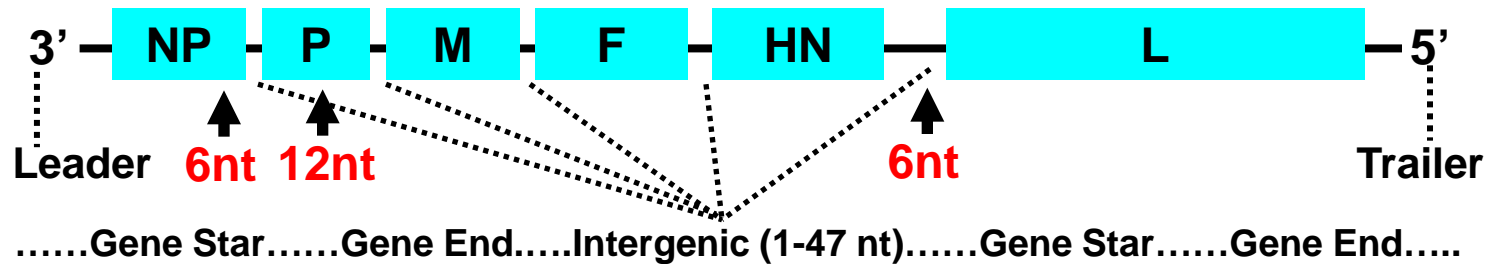

- 单股负链不分节段RNA病毒
- 副粘病毒科，禽腮腺炎病毒属
- 基因组全长15186/15192/15198 nt

- F为毒力主要决定基因
- M: 病毒形态形成
- F/HN

研究背景

F/HN 囊膜蛋白

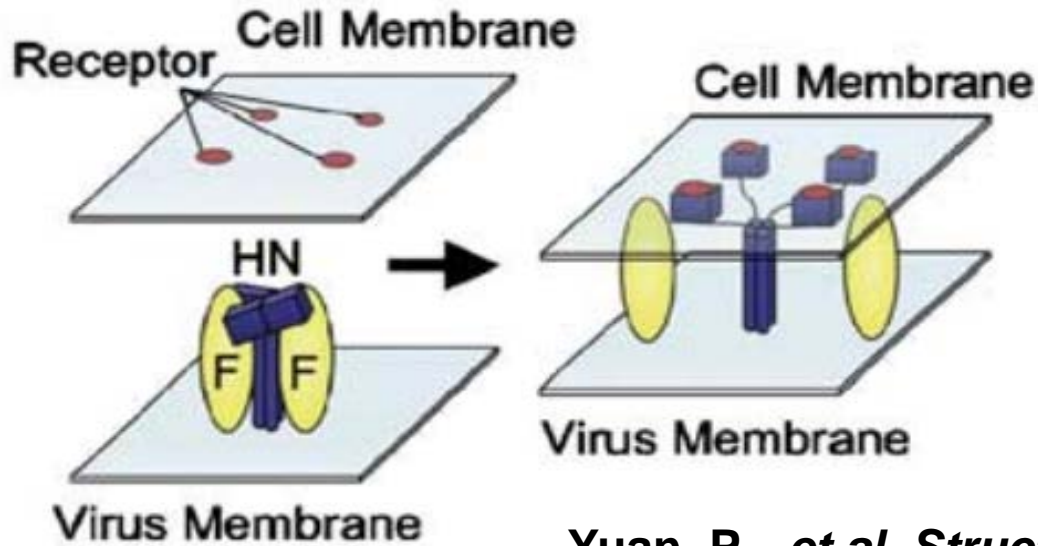

Yuan, P., *et al. Structure*, 2005

F

- 膜融合
- 介导病毒进入细胞
- 毒力因子、保护性抗原

HN

- 受体结合
- NA活性
- 保护性抗原

项目背景

- F基因是NDV的主要毒力决定基因，以前的研究表明：强弱毒F蛋白裂解位点氨基酸序列各不相同，
- 强毒株序列为：112R/K-R-Q-K/R-R-F117
（在Q两侧各有一对碱性氨基酸）
- 弱毒株序列为：112G/E-K/R-Q-G/E-R-L117
（以中性氨基酸取代了强毒株中的碱性氨基酸）

科学问题

- 最近分离的一株鸽源NDV，其F基因虽然具有强毒序列特征，但其毒力较低，且通过反向遗传手段，用标准强毒的F基因替换后，其毒力仍然较低（Dortmans J. C, etal）。
- 科学问题：鸽源NDV毒力是否与另外一中囊膜蛋白—血凝素神经氨酸酶(HN)有关???



测序及序列分析

设计针对保守区域的引物，扩增出HN CDS，分别与强毒株和弱毒株相应序列进行比对。

Pairwise Alignment Result

LENGTH	SCORE	IDENTITY	SIMILARITY	GAPS
1716	8527.0	1482/1716 (86.4%)	1482/1716 (86.4%)	0/1716 (0.0%)

```

1  atggaccgctgcagttagccagcttgcggttagagaatgaagaaagagaagc 50
1  |||...|||...|||...|||...|||...|||...|||...|||...|||... 50

51  aaagaataacatggcgtttgtattccggatcggcaatttacttttaatag 100
51  .|.|.|.|.|.|.|.|.|.|.|.|.|.|.|.|.|.|.|.|.|.|.|.|.|.|. 100
51  gaagagcaacatggcgtttgtattccggatcggcaatttacttttaataa 100

101  taataaaccttagcaatctctggcagcgccttggtatatagcaggggt 150
101  |.|.|.|.|.|.|.|.|.|.|.|.|.|.|.|.|.|.|.|.|.|.|.|.|.| 150
101  tgatgaaccttagctatctctggcagcgccttggtatatagcaggggt 150

151  agcaacggcggcgacacctgttggcacaacaactgtgatctctagggcaga 200
151  |||...|||...|||...|||...|||...|||...|||...|||...|||... 200
151  agtaacggcggcgacacctgttggcacaacaactgtgatctctagggcaga 200

201  ggaaaagattacatctgcactcagttctaaatacaagatgtagtagagga 250
201  |||...|||...|||...|||...|||...|||...|||...|||...|||... 250
201  ggcaacggattacgtcttactcagttctaaatacaagatgtagtagagga 250

251  tatataagcaaggtggcccttgagctcaccattggcgttgcaaaaacatgaa 300
251  |||...|||...|||...|||...|||...|||...|||...|||...|||... 300
251  tataaagcaaggtggcccttgagctcaccattggcgttgcaaaaacatgaa 300

301  tctgtaattatgaatgcaataacgtctctcttctaatcaatcaatggagc 350
301  |||...|||...|||...|||...|||...|||...|||...|||...|||... 350
301  tctataatcaatgaatgcaataacgtctctcttctaatcaatcaatggagc 350

351  tgcaaaaataagcgggtgtggggcaacctgtctatgacccagattacatg 400
351  |||...|||...|||...|||...|||...|||...|||...|||...|||... 400

```

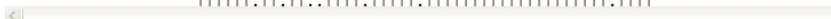

强毒 (Herts, 33/56) 与鸽源毒

Pairwise Alignment Result

LENGTH	SCORE	IDENTITY	SIMILARITY	GAPS
1737	8075.0	1412/1737 (81.3%)	1412/1737 (81.3%)	24/1737 (1.4%)

```

1  atggaccgctgcagttagccaaagttgcggttagagaatgatgaagagagggc 50
1  |||...|||...|||...|||...|||...|||...|||...|||...|||... 50

51  aaaaaatacaatggcgtttgatattccggattgcaattttattcttaadag 100
51  .|.|.|.|.|.|.|.|.|.|.|.|.|.|.|.|.|.|.|.|.|.|.|.|.|.|. 100
51  gaagagcaacatggcgtttgatattccggattgcaattttattcttaadag 100

101  tagtgaacctggcctatatctgttagccctcccttttatatagcaggggt 150
101  |.|.|.|.|.|.|.|.|.|.|.|.|.|.|.|.|.|.|.|.|.|.|.|.|.| 150
101  tgatgaaccttagctatctctgttagccctcccttttatatagcaggggt 150

151  agcacaccttagcgtatttctaggcacaaccagcagcattccagggcaga 200
151  |||...|||...|||...|||...|||...|||...|||...|||...|||... 200
151  agtaacggcggcgacacctgttggcacaacaactgtgatctctagggcaga 200

201  agaaaagattacatctgcactcagttctaaatacaagatgtagtagagga 250
201  |||...|||...|||...|||...|||...|||...|||...|||...|||... 250
201  ggcaacggattacgtcttactcagttctaaatacaagatgtagtagagga 250

251  tatataagcaaggtggcccttgagctcaccattggcgttgcaaaaacatgag 300
251  |||...|||...|||...|||...|||...|||...|||...|||...|||... 300
251  tataaagcaaggtggcccttgagctcaccattggcgttgcaaaaacatgaa 300

301  accacaattatgaacgcaataaacctctctcttctaatcaatcaatggagc 350
301  .|.|.|.|.|.|.|.|.|.|.|.|.|.|.|.|.|.|.|.|.|.|.|.|.|.|. 350
301  tctataatcaatgaatgcaataaacctctctcttctaatcaatcaatggagc 350

351  tgcaaaaacacagctgggtgggggcaaccttatccatgacccagattatag 400
351  |||...|||...|||...|||...|||...|||...|||...|||...|||... 400

```

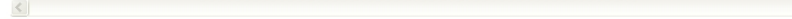

弱毒 (LaSota) 与鸽源毒

跨膜区预测

Tmap

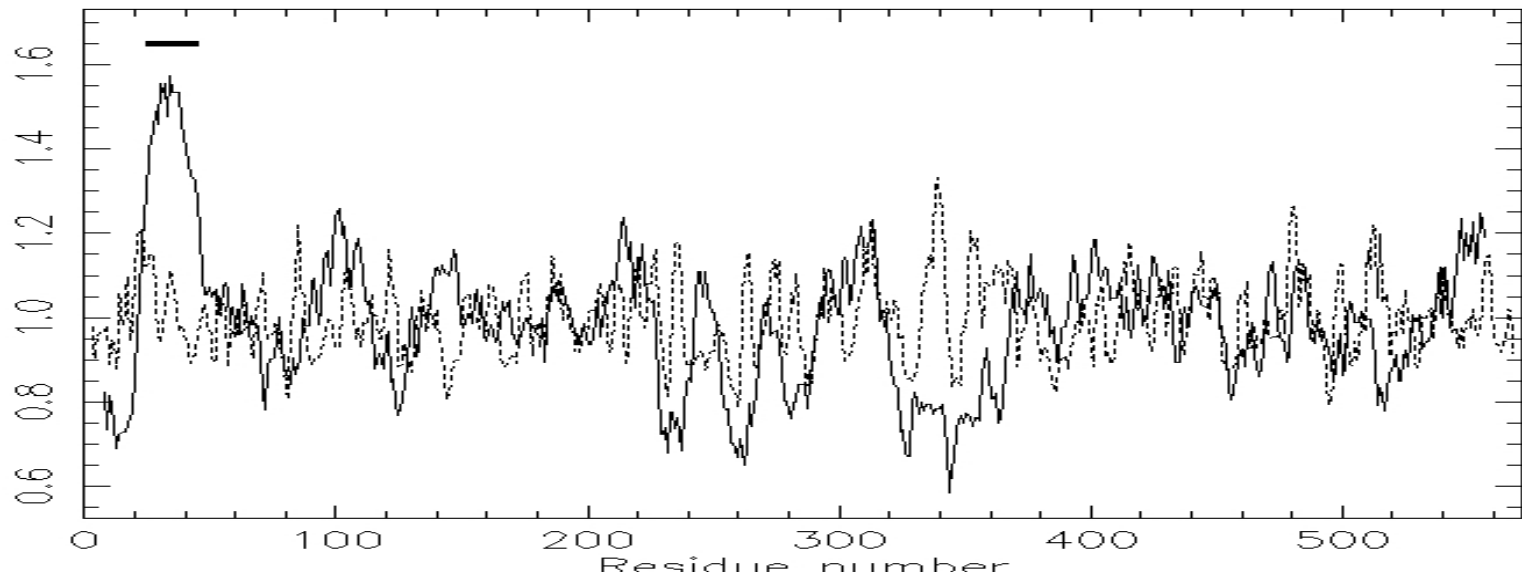

TMHMM posterior probabilities for WEBSEQUENCE

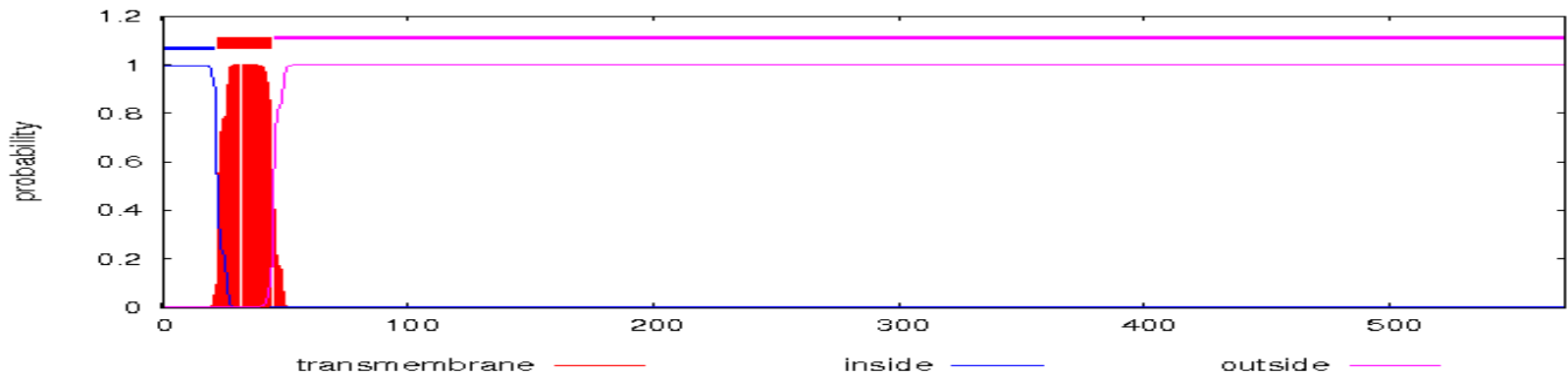

信号肽预测

SignalP-4.1 prediction (euk networks): NDV,Pigeon,HN_JX486554.1.seq

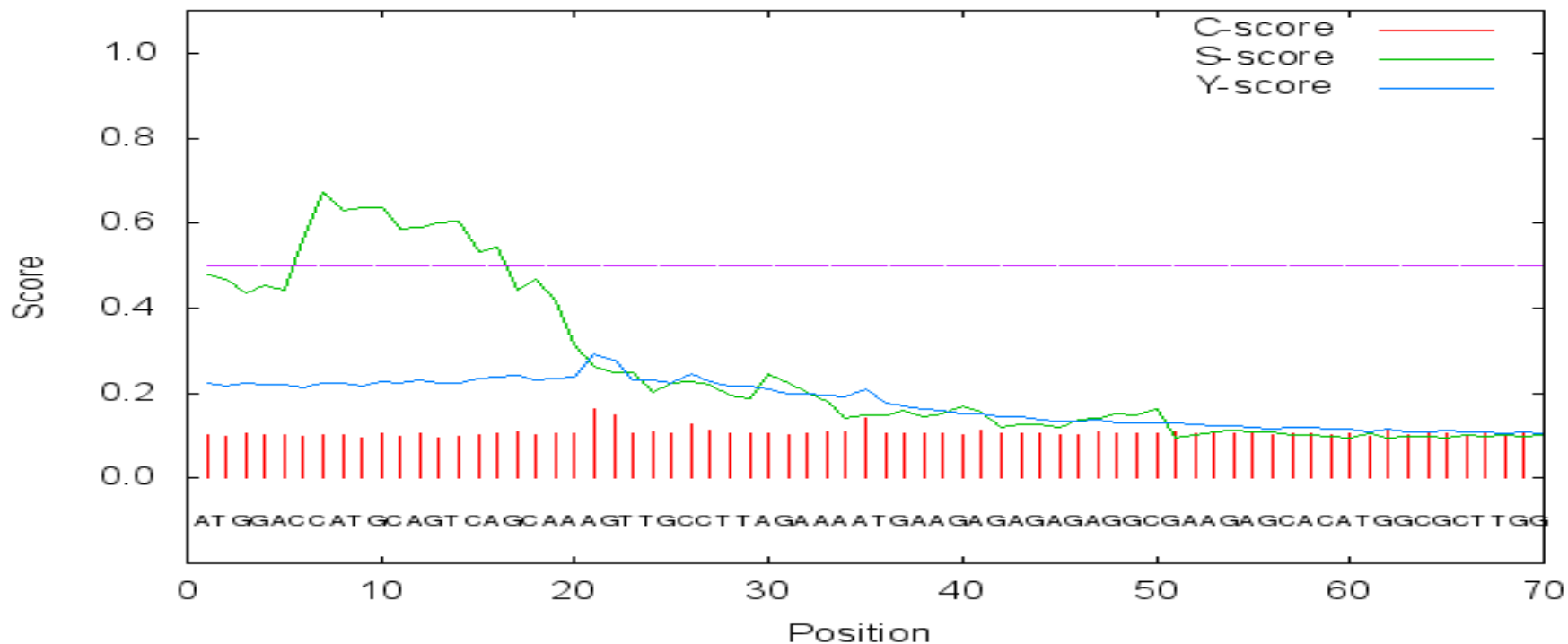

Evolutionary Analysis of phylogenetic tree by MEGA5

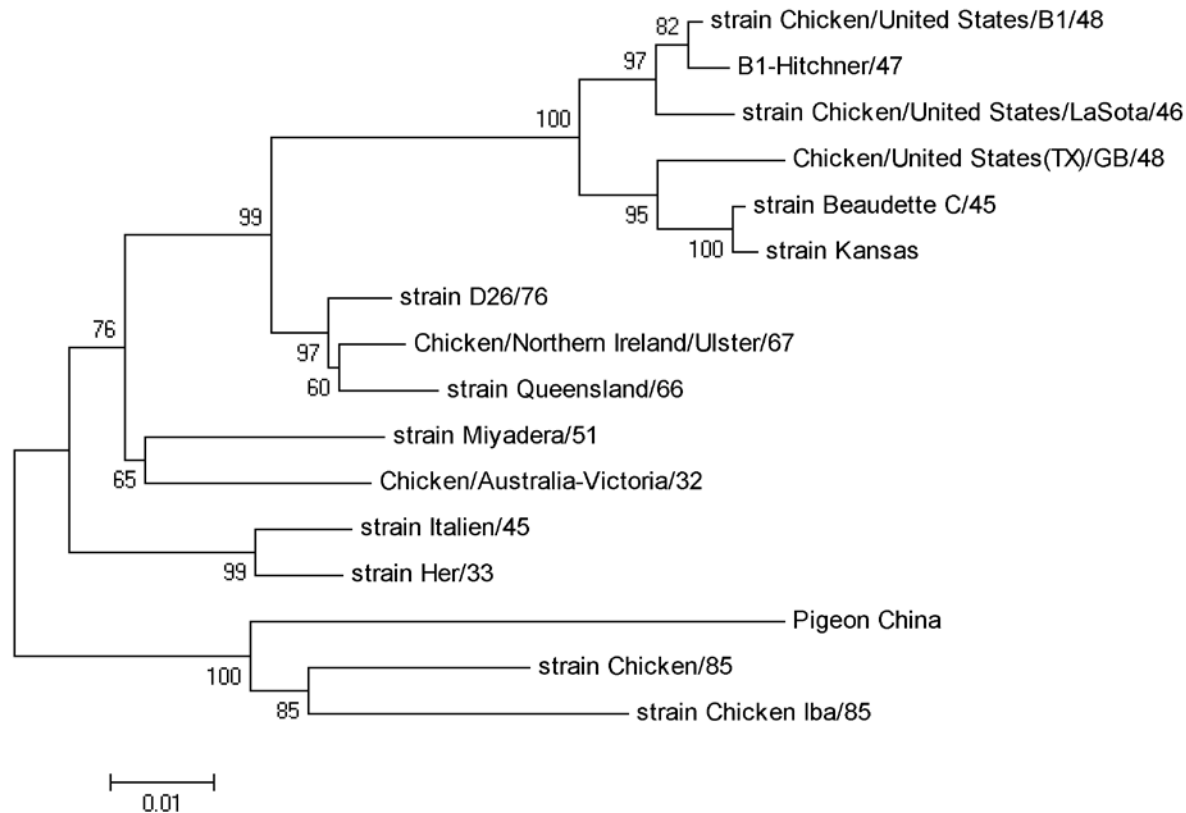

- Figure. Evolutionary relationships of HN in NDV
- Saitou N. and Nei M. (1987). The neighbor-joining method: A new method for reconstructing phylogenetic trees. *Molecular Biology and Evolution* 4:406-425.

结构预测

Structure of the Ulster Strain Newcastle Disease Virus Hemagglutinin-Neuraminidase Reveals Auto-Inhibitory Interactions Associated with Low Virulence

DOI:10.2210/pdb4fzh/pdb

Primary Citation

Structure of the ulster strain newcastle disease virus hemagglutinin-neuraminidase reveals auto-inhibitory interactions associated with low virulence.

Yuan, P., Paterson, R.G., Leser, G.P., Lamb, R.A., Jardetzky, T.S.

Journal: (2012) Plos Pathog. 8: e1002855-e1002855

PubMed: 22912577

PubMedCentral: PMC3415446

DOI: 10.1371/journal.ppat.1002855

Search Related Articles in PubMed

PubMed Abstract:

Paramyxovirus hemagglutinin-neuraminidase (HN) plays roles in viral entry and maturation, including binding to sialic acid receptors, activation of the F protein to drive membrane fusion, and enabling virion release during virus budding. HN can thereby directly influence virulence and in...

[[Read More & Search PubMed Abstracts](#)]

4FZH

- Display Files ▾
- Download Files ▾
- Share this Page ▾

Biological Assembly 1 ?



3D View

More Images...

Biological assembly 1 assigned by authors

Downloadable viewers:

模版

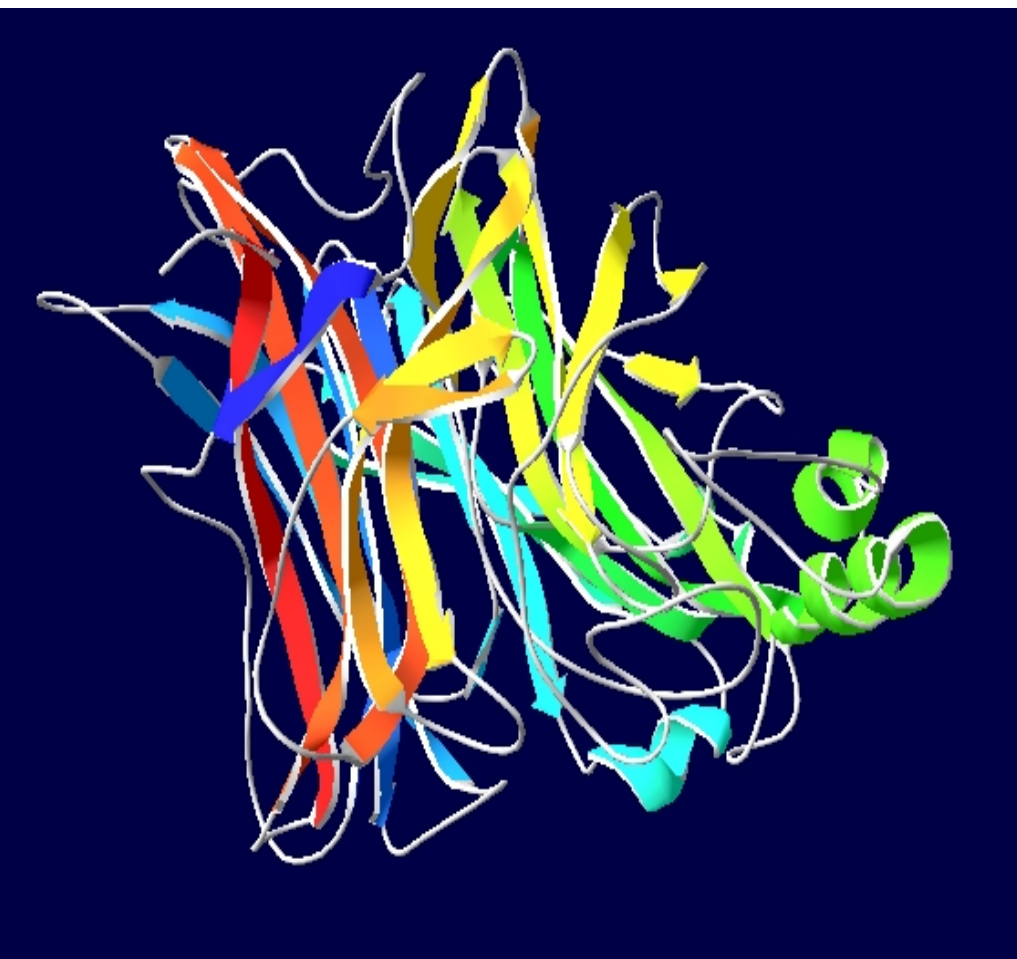

同源模建



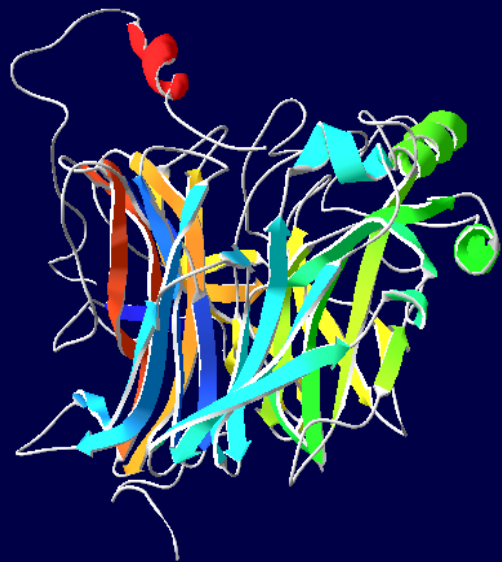

侧面

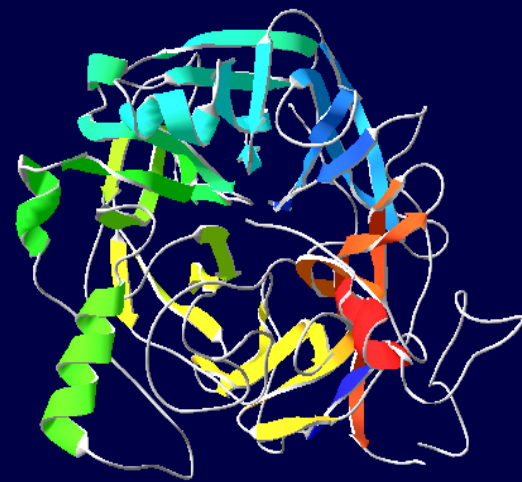

底部

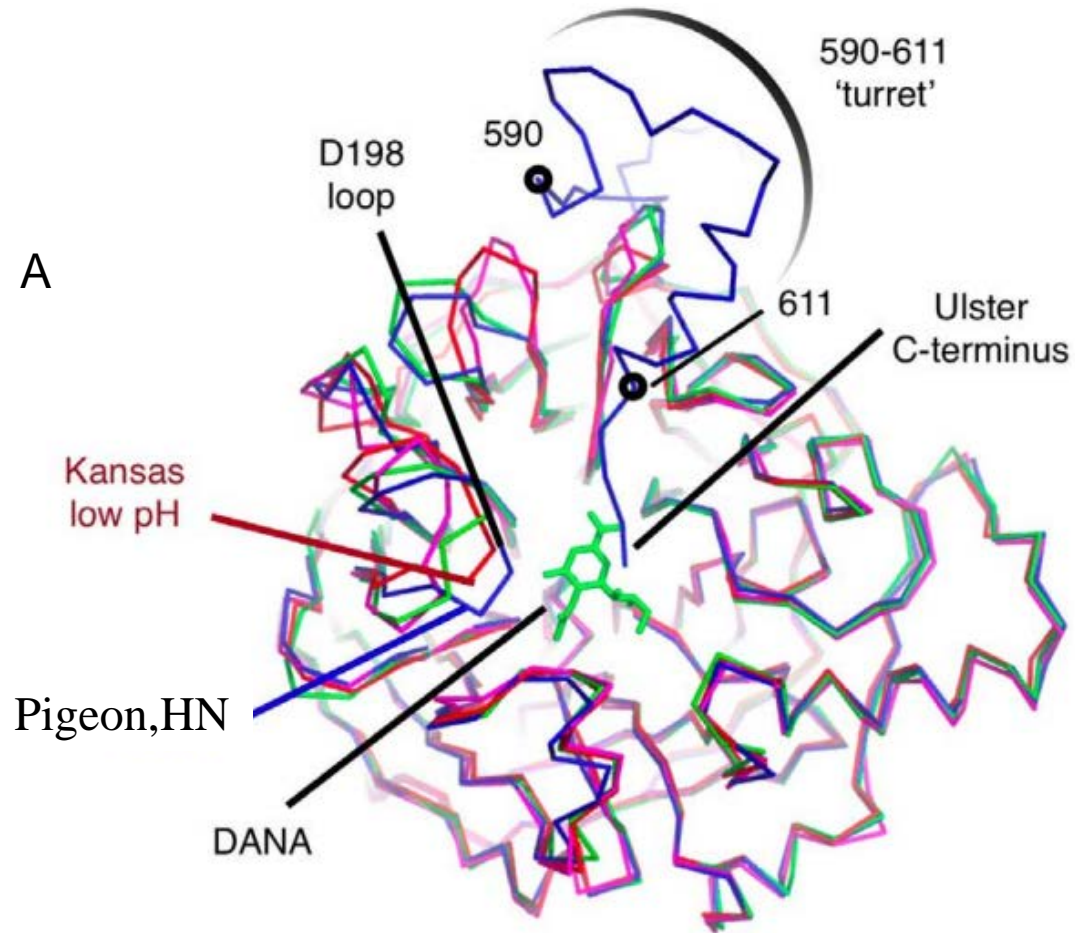

C末端（蓝色高亮），刚好位于；配体结合位点的上端

B

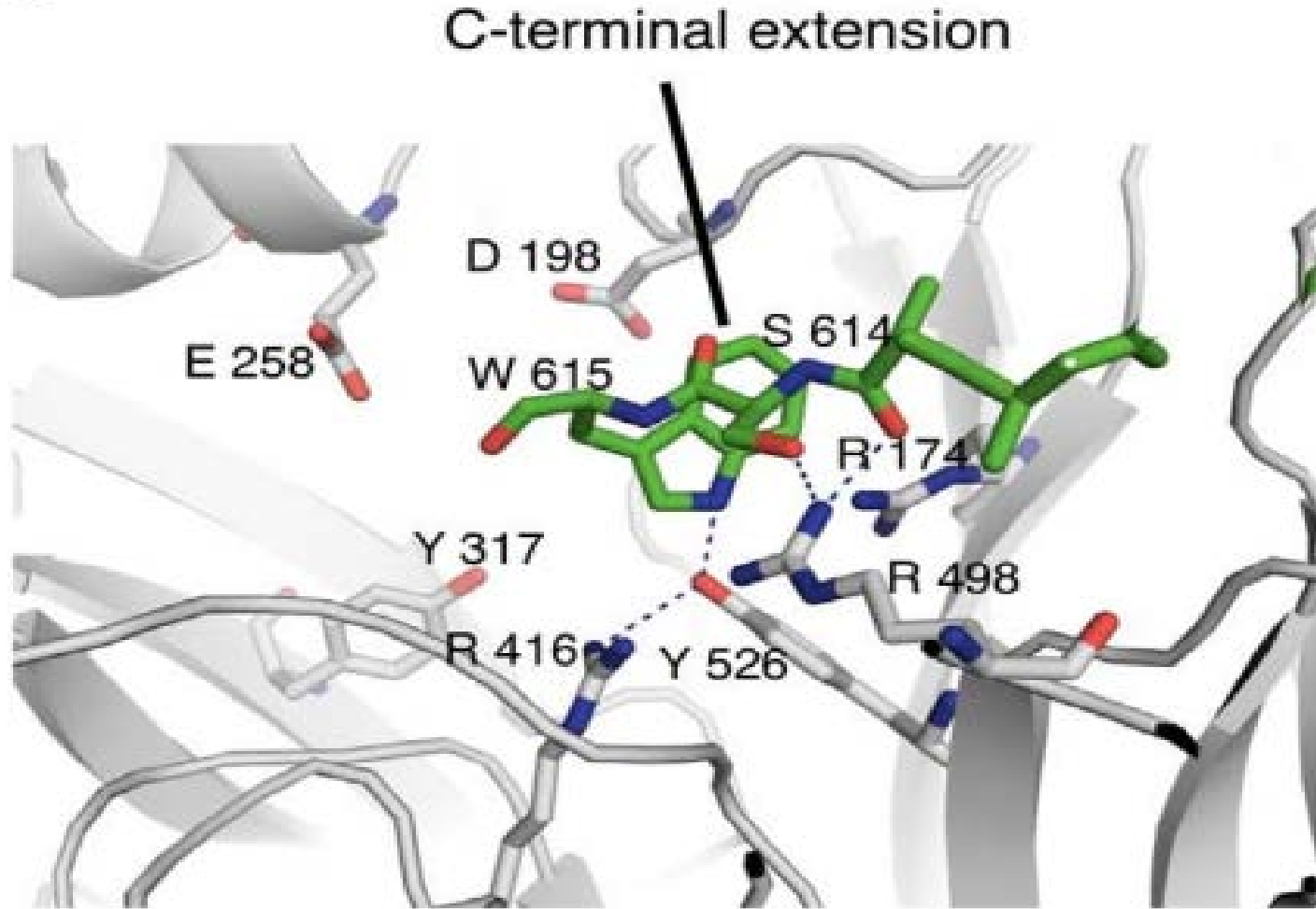

推测：D198阻挡了HN和唾液酸受体的结合空间（blocking）

结论

- 鸽源NDV的HN蛋白与已经解析的弱毒株（Ulster）的结构相似度较高。
- D198（Asp，天冬氨酸）刚好在HN的C末端的延深部位，可能刚好阻挡了HN与受体结合的活性部位，这也可能会解释为什么新分离到的鸽源NDV具有强毒特征的F基序，但表现出低毒力的原因。

下一步试验验证

- 基因替换/氨基酸突变--病毒拯救--功能验证

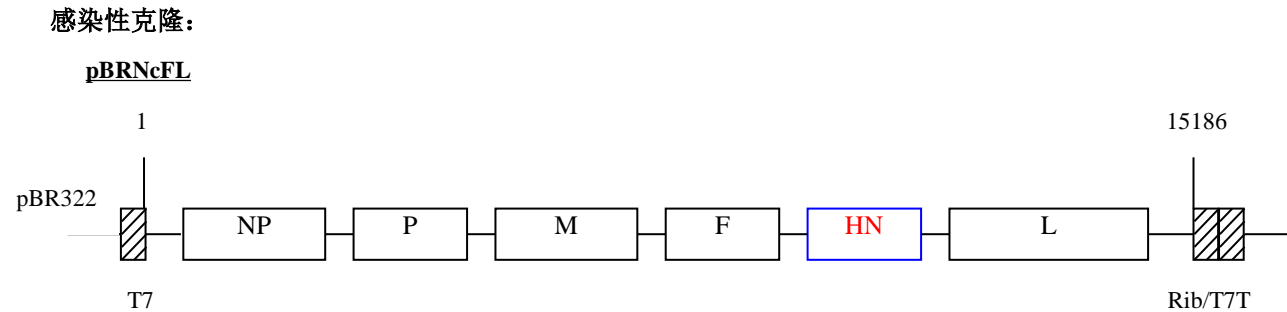

Reference

- 1. Saitou N. and Nei M. (1987). The neighbor-joining method: A new method for reconstructing phylogenetic trees. *Molecular Biology and Evolution* 4:406-425.
- 2. Felsenstein J. (1985). Confidence limits on phylogenies: An approach using the bootstrap. *Evolution* 39:783-791.
- 3. Zuckerkandl E. and Pauling L. (1965). Evolutionary divergence and convergence in proteins. Edited in *Evolving Genes and Proteins* by V. Bryson and H.J. Vogel, pp. 97-166. Academic Press, New York.
- 4. Tamura K., Peterson D., Peterson N., Stecher G., Nei M., and Kumar S. (2011). MEGA5: Molecular Evolutionary Genetics Analysis using Maximum Likelihood, Evolutionary Distance, and Maximum Parsimony Methods. *Molecular Biology and Evolution*

致 谢

- 敬爱的罗老师！
- 李坤同学
- 曹小安同学



小组成员

- 王 琪
- 李连峰
- 张晓战
- 董书伟

